

## An Example in Steel Casting

### The One Person Hitch Housing for the 2 ½ and 5 Ton Trucks

#### The Application –

The one person hitch housing is part of an improved hitch/frame design for the military's 2½ and 5 ton trucks, used for towing weapons systems, cargo trailers, and other payloads. The hitch housing acts as an alignment and locking fixture for connecting the trailer tow hook to the truck tow bar. Through a redesign of the housing to provide lateral motion to the tow bar during hook-up, the new hitch permits one-person operation, reduces hitch-up time, and provides for safer handling.

#### Hitch Housing Description

The hitch housing assembly is attached to the truck frame. The towing draw bar moves within the assembly during hook-up, which permits the draw bar to “swing” laterally to align with the trailer tow bar. After the trailer is connected, the draw bar self-aligns and locks in the hitch housing for towing.

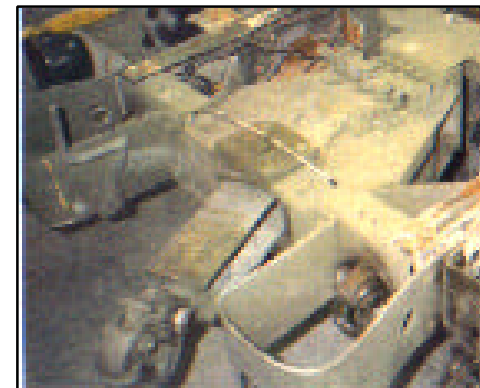

## The Challenge

The hitch housing has a plate geometry with vertical alignment bars and rib stiffeners. It weighs approximately 60 lbs with nominal dimensions of 18" x 20" x 5". The housing is made with SC 8630 steel and sees loads as high as 15,000 lbs (for the 5 ton truck). The first prototypes of the hitch housing were fabricated steel assemblies, consisting of more than 35 pieces bolted and welded together. The assembly required 4-6 hours of alignment effort during installation. The projected production cost of the steel fabrication assembly was \$5000 per unit.

## The Metalcasting Solution

The challenge was to improve the hitch housing assembly. The goals of the metalcasting design approach were to --

- Reduce the number of parts in the assembly and lower the weight.
- Decrease the final, manufactured cost
- Provide faster, more precise alignment/adjustment procedures during assembly on the truck
- Improve the hitch durability.





**What questions did the Casting Engineer ask in considering metalcasting for the One Person Hitch Housing?**

- Is the component design optimized for casting manufacturability, as well as performance?

*The casting (and its casting pattern) must be designed so that directional solidification and casting soundness are promoted, tooling costs are minimized, and stress concentrators are reduced.*

- **How does the alloy requirement affect the casting design and fabrication of this component?**

*In casting steel alloys, the casting designer has to consider how the steel flows into the mold to provide rapid fill without turbulent flow. The mold must have properly placed and sized risers to feed liquid metal into casting during solidification.*

- The casting engineer has the job of determining how to produce the component as a metal casting.
- The casting engineer studies the original designs and determines how much latitude he has in fit and function to design for manufacturability and casting.
- Once those considerations are defined, he goes through a specific set of decision steps to develop a casting design and a casting pattern/cores for making the mold.

1. Locate the parting line and orient the component in the mold.

2. Review the design for draft angles and sharp radii.

3. Identify and eliminate isolated hot spots in the component.

4. Promote directional solidification in the component.

5. Place and size the risers for adequate metal feed during solidification.

6. Place and size the runners/gates to promote high volume, low velocity metal flow into the casting.

## Parting Line and Orientation in the Mold

**Design Criteria** -- The pattern has to be planned and designed so that –

- The parting line is straight and in the largest cross-sectional plane of the casting.
- The component face with the greatest surface detail is in the drag, because fluid fill is better in the drag and non-metallic inclusions tend to segregate at the top of the casting.
- The pattern is oriented for smooth, non-turbulent fluid flow.
- The need for cores is minimized/eliminated.

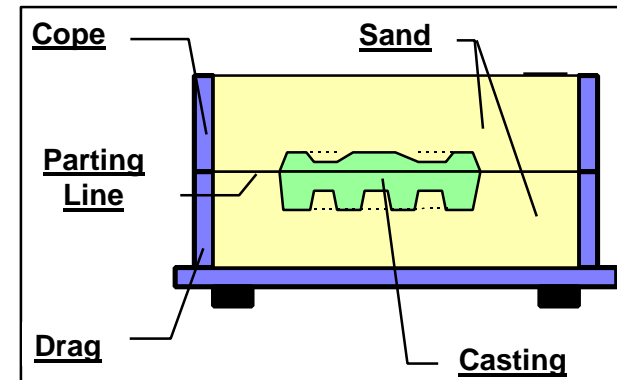

## Design Options --

Three pattern orientations and parting line options are shown. Choose the one that best meets the design criteria.

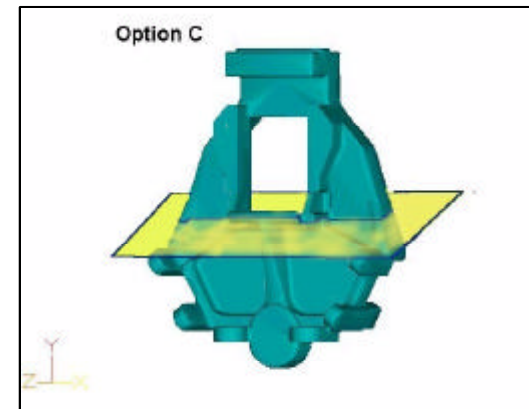
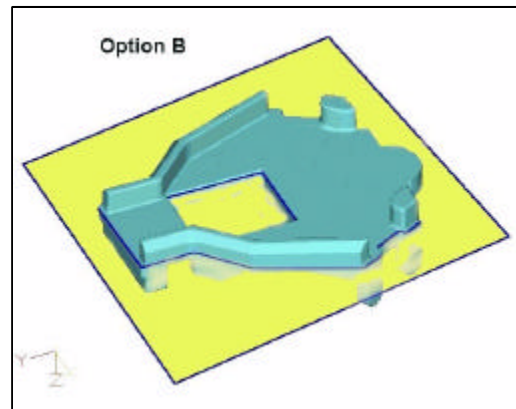
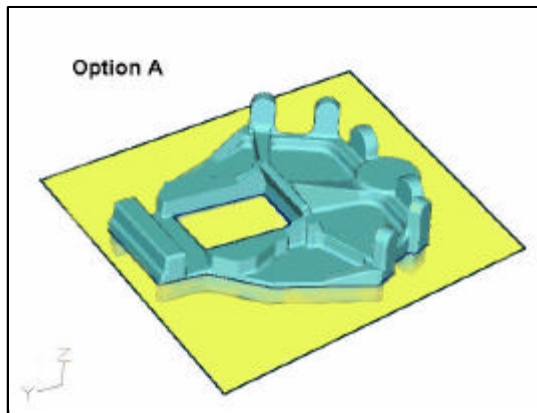

OPTION A –

The parting line is correctly oriented here, but the more complex face is facing up where it will be more difficult to fill. Choose another option

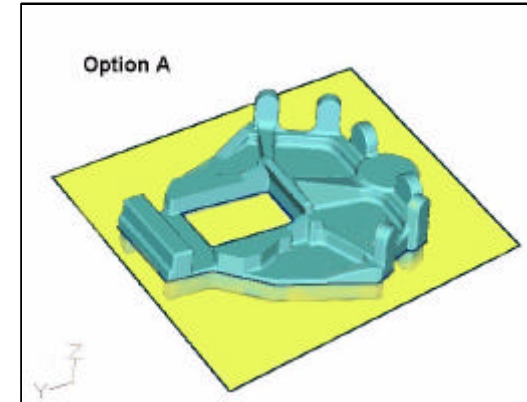

OPTION B --

This is the preferred design for orientation and the parting line. The component is oriented horizontally, the parting line is in the largest cross section of the piece, and the more complex face is facing down where it will be the first to fill

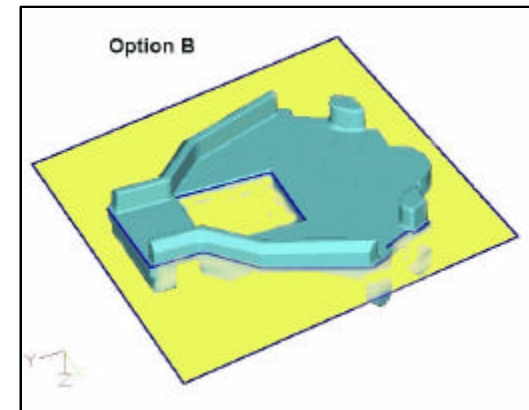

OPTION C –

The component is oriented vertically here, rather than horizontally. This will be a difficult mold to fill with metal because of its orientation. And it will be more expensive because extra cores will be required to form the bosses and ribs. Choose another option

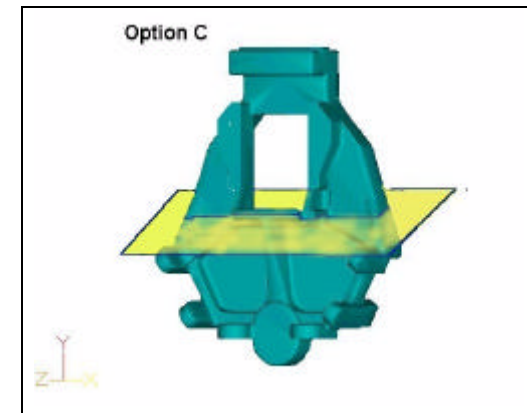

## Draft Angles, Radii, and Fillets

**Design Criteria** -- The component has to be designed so that --

- Vertical surfaces have the proper draft angle so the mold can be drawn from the pattern. A draft angle of  $1^\circ$  is common.
- Sharp radii and fillets are smoothed and rounded to avoid turbulent metal flow and to eliminate stress concentrations.

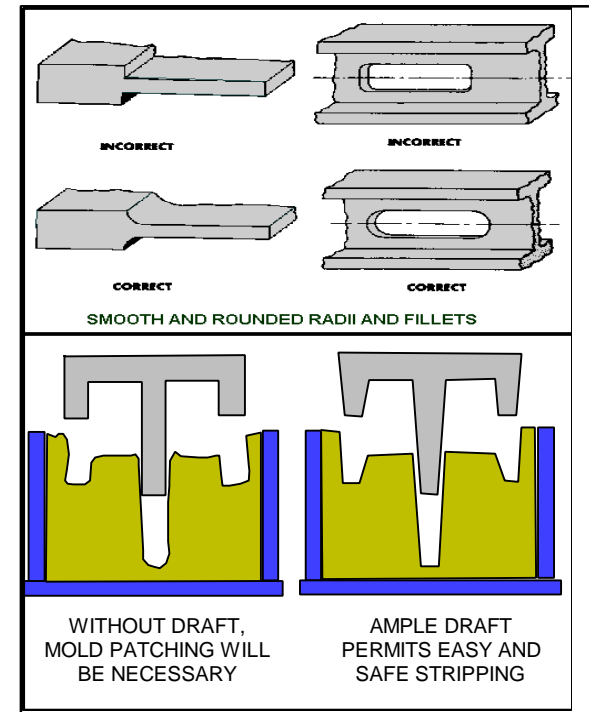

## Draft Angles, Radii, and Fillets

**Design Options** -- Five features on the component are highlighted for consideration. Consider how and where draft angle, radii, and fillets need to be checked on each of these features.

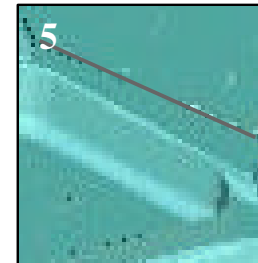
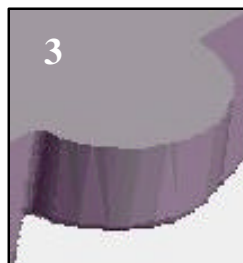
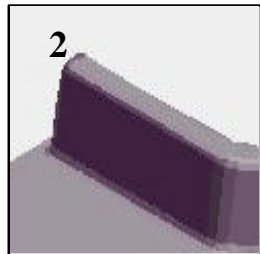
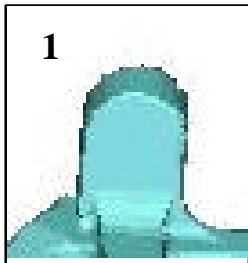
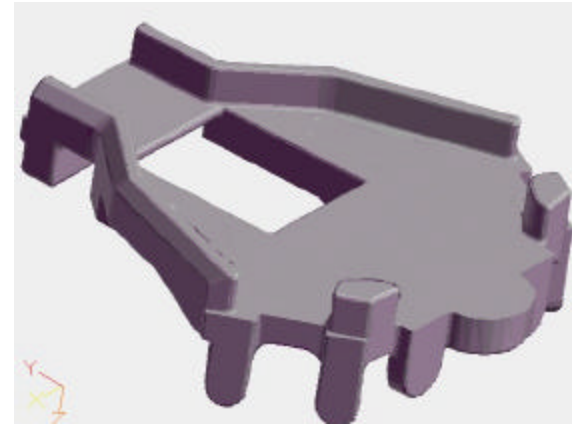
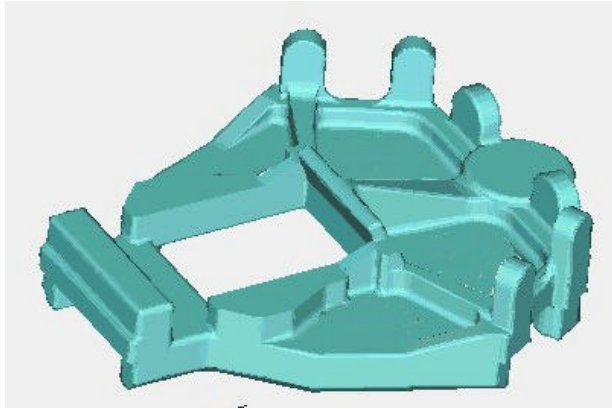



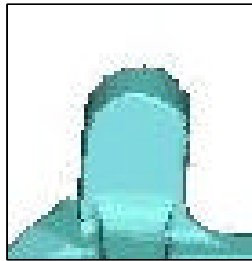

This vertical tab is deep enough that its vertical dimensions need to have proper draft. The round top section has sufficient radius for good flow and fill.

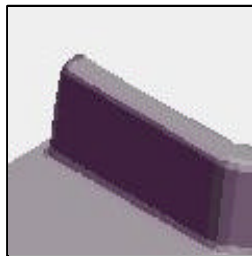

This side rib is a major feature which will have to draw cleanly from the mold. Check the draft angle carefully.

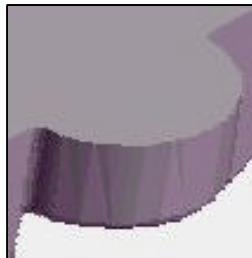

This boss is situated on the parting line and needs very little draft. Its radius is large enough for good fill and flow.

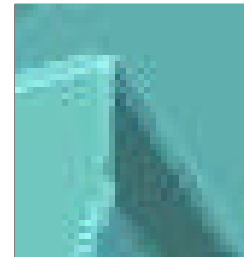

This corner indent in the center of the plate could be a problem area for good fill. Insure that there is a generous fillet in the corner and a sufficient radius on the edge.



This is a stiffening rib in the center of the plate. It is relatively shallow and has a good fillet at the root. No change is necessary.

## Eliminate or Reduce Isolated Hot Spots

**Design Criteria** -- Review the design, looking for isolated thick sections which could be “hot spots” where shrinkage porosity might form. Add “padding” to promote soundness and aid metal feed into the “hot spot.”

- As metal in thin sections solidifies first, the thicker section will be isolated from the molten metal feed and shrinkage porosity will form in the thick section.
- The thin connecting section into the thicker section should be “padded” to improve the thermal connection and metal flow into the “hot spot”.
- Padding should be integrated into the functional design, so that it does not have to be removed after casting.

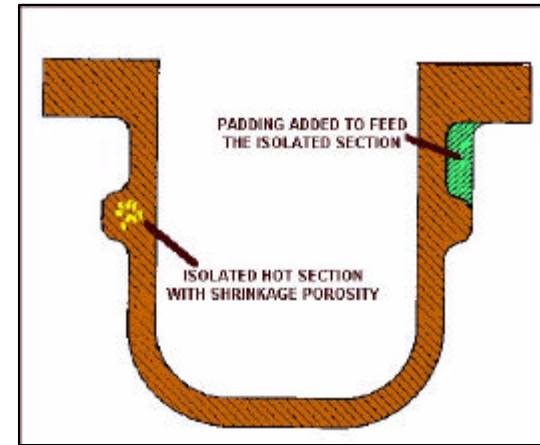

**Design Options** -- The original hitch design has two isolated “bosses” on each side of the forward flat section. These were obvious “hot spots” which need to be “padded” to promote soundness. Select a padding option that will eliminate the hot spots and will integrate into the functional design.

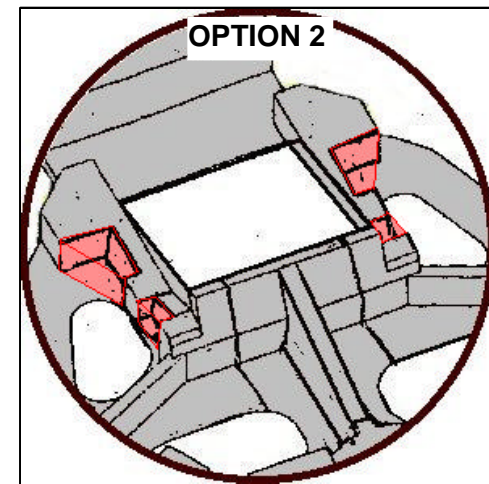
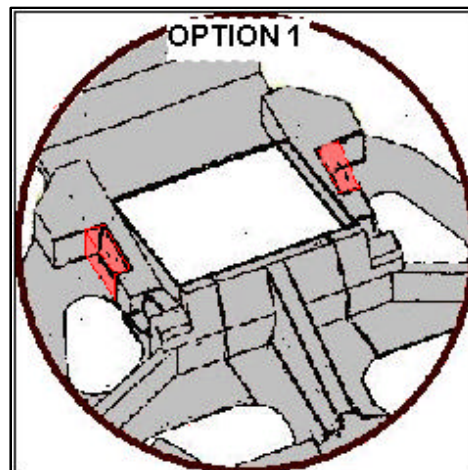
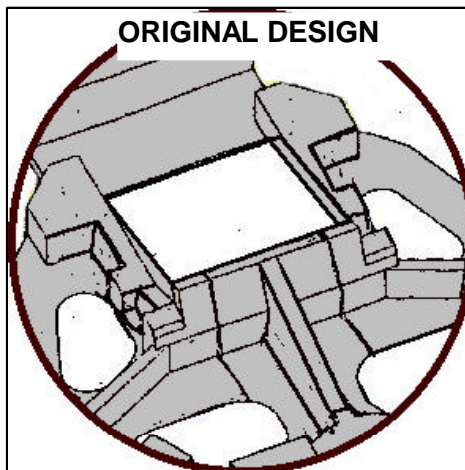

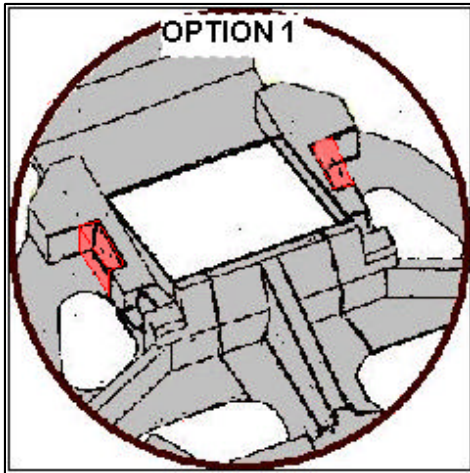

**Option 1 -**

The padding is not sufficient here to feed into the first isolated section and eliminate the hot spot. In addition the smaller hot spot closer to the center rib is still isolated. Choose another option

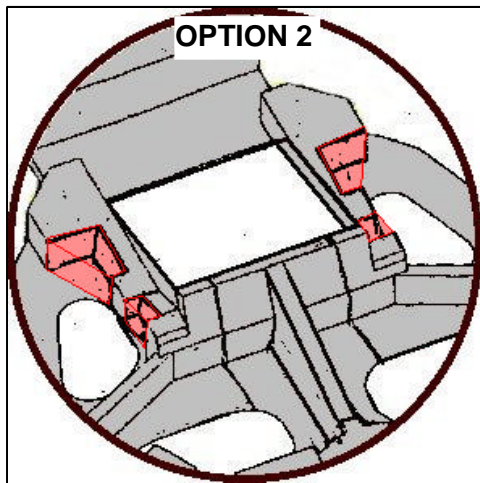

**Option 2 -**

The padding here is properly sized and placed to provide sufficient metal feed into the thicker section and to eliminate the thermal isolation. All the hot spots have been connected with pads. The pads are also integrated into the design and do not have to be removed after casting.

## Promote Directional Solidification

**Design Criteria** -- Review the design, looking for flat sections that can be lightened and long thin ribs that need to be tapered to promote directional solidification

- Large flat sections are difficult to feed and to develop good directional solidification. Lightener holes eliminate the problem of isolated flat sections; they also save weight. But they need to be placed in “non-structural” areas.
- Adding taper along a rib or section from the cold region to the hot region promotes directional solidification and prevents shrinkage pores.

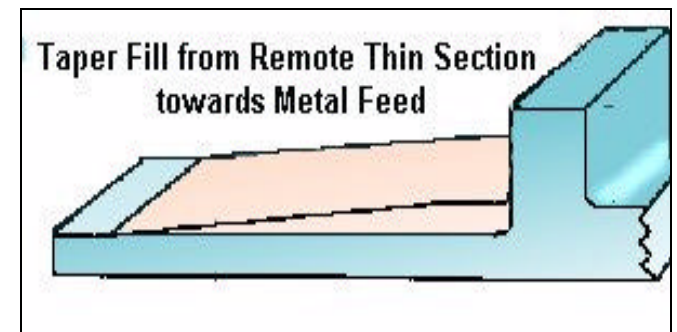
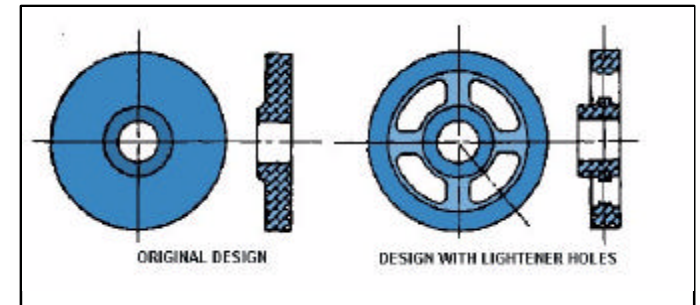

**Design Options --**

**LIGHTENER HOLES**

There are FIVE large flat sections (A, B, C) in the hitch plate. Choose appropriate sections for lightener holes.

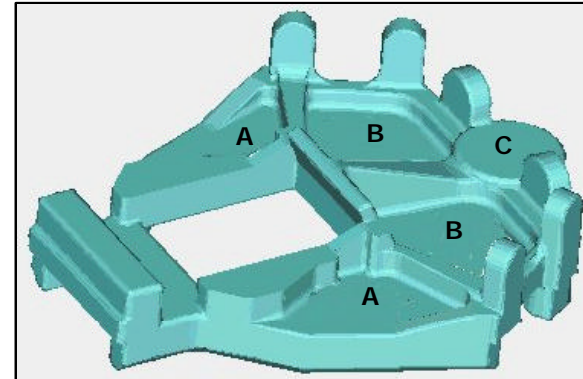

**TAPERS FOR DIRECTIONAL SOLIDIFICATION**

There is one long thin rib that extends from the flat boss on the periphery to the center rib. Add a suitable taper to promote directional solidification on that rib.

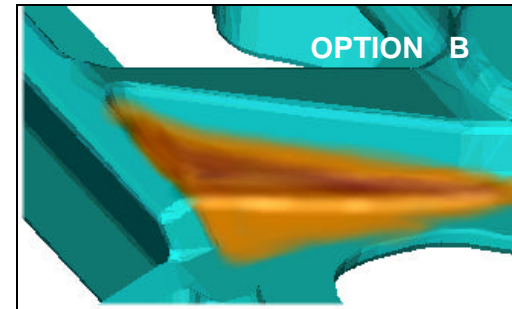
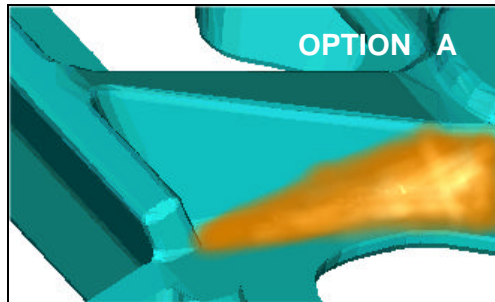
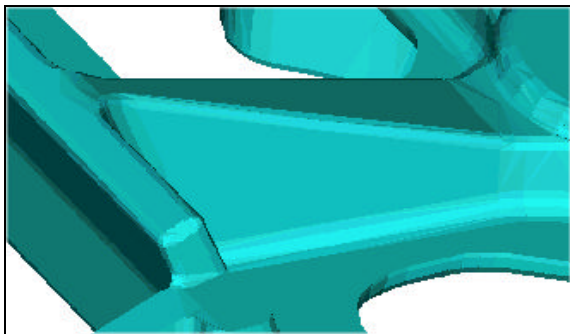

## Lightener Holes

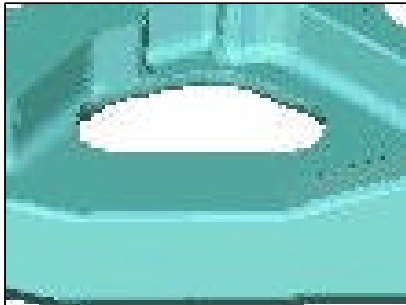

Option A -- This region is a good location for a lightener hole, reducing metal feed and saving weight

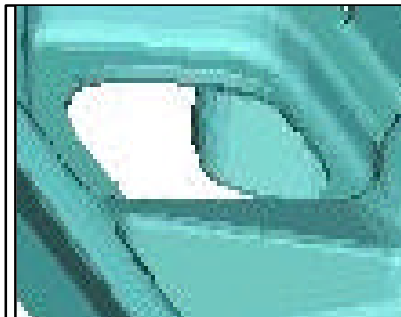

Option B -- This region is a major flat section which does not bear load and which is suitable for a lightener hole.



Option C – This flat is a major loading point which bears a direct load. It should not be thinned out.

## Tapered Sections for Directional Solidification

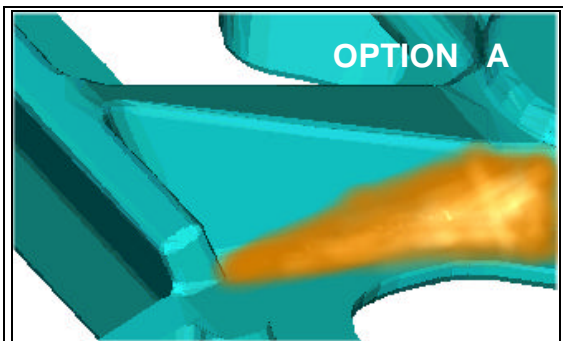

Option A- This taper is correct, filling in at the remote section and building up towards the metal feed on the outer perimeter

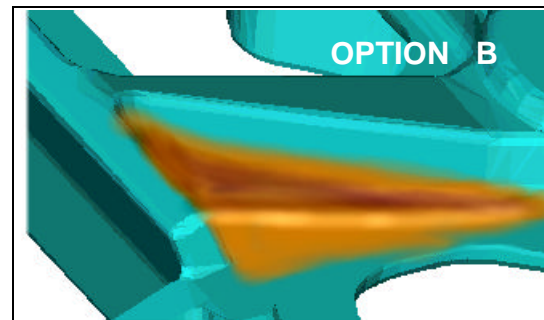

Option B- This taper is incorrect, completely filling in the cold, remote section and thinning towards the feed section on the outer perimeter



## **BASELINE PATTERN DESIGN**

After reviewing the component design from a casting perspective, the patterns for the cope and drag sections of the mold are prepared

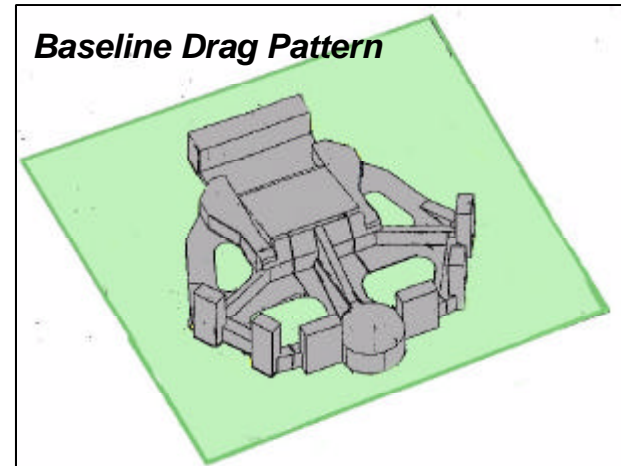
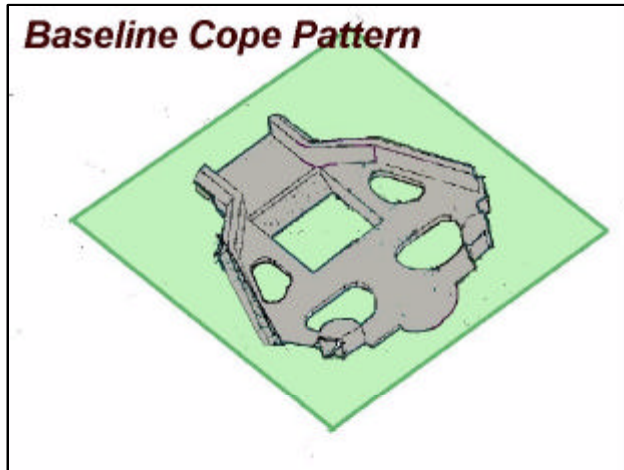

The next step is to add casting features to the pattern to accommodate for metal solidification and flow. These features are risers, gates, runners, and sprues.

## Riser Sizing and Placement

**Design Criteria** -- Risers are reservoirs of molten metal to supply the solidifying, contracting molten metal in the casting with make-up metal. They are used to prevent internal or external voids due to shrinkage.

- Risers are placed and sized to provide sufficient metal flow into the mold during cooling to compensate for shrinkage.
- Steel castings require shorter metal flow paths and larger amounts of metal to compensate for high shrinkage. This requires that multiple risers be evenly distributed around the casting.

**Design Options** -- Two riser options are provided.

Choose the riser design for the cope pattern that provides the shortest, most direct metal feed during cooling.

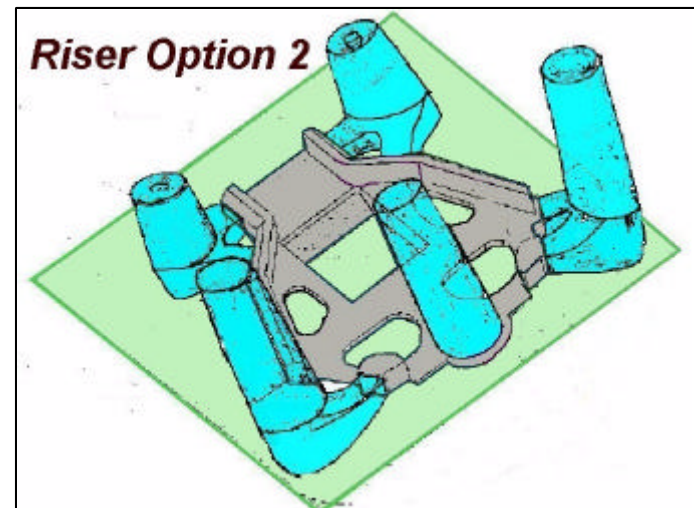
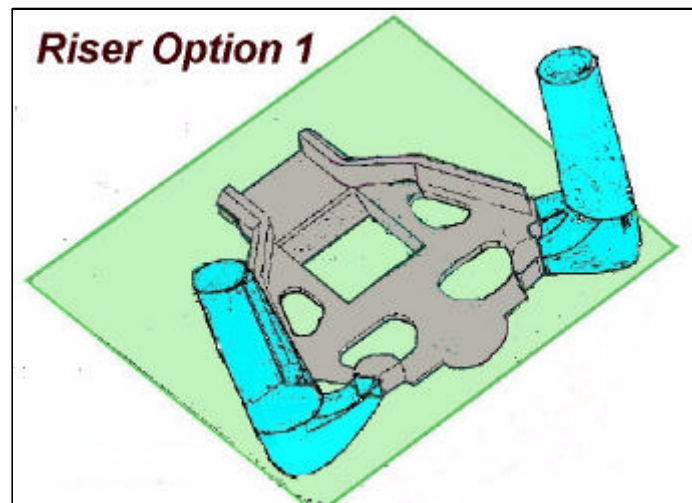
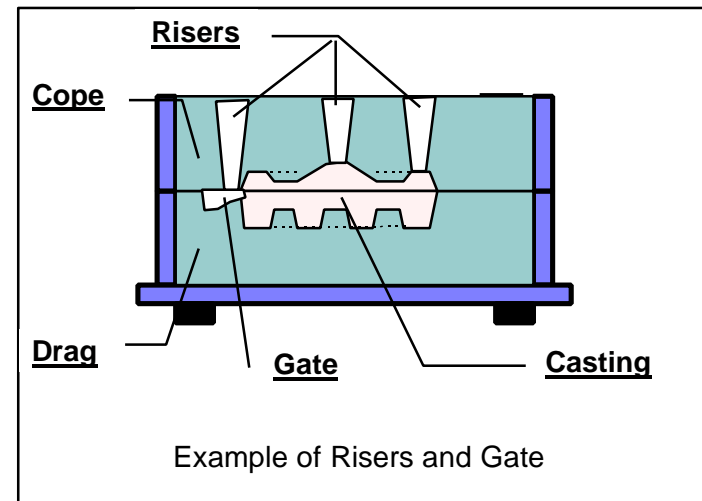



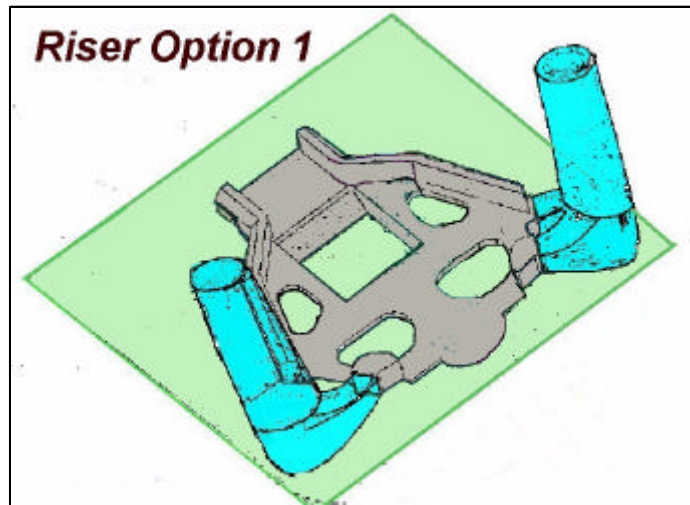

**Option 1 -**

The use of two risers does not provide sufficient volume nor short enough flow path to prevent shrinkage porosity in the steel casting. The far section of the housing will not have enough metal feed during solidification. Choose the other option.

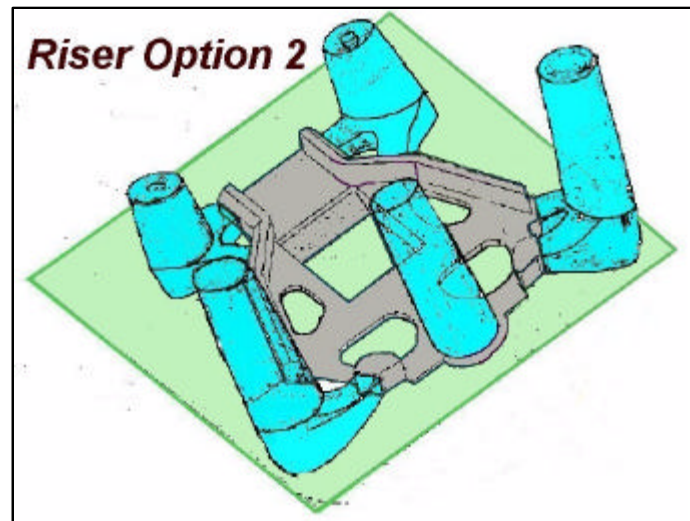

**Option 2 -**

This is a good design for the risers. They are well located around the casting with short flow paths and there is sufficient volume to provide the needed molten metal to the different sections. Four of the risers are placed over the gates, so that they can be easily removed from the final casting.

## Gating System

**Design Criteria** -- The gating system (sprues, runners, and gates) provides paths for the molten metal to flow into the mold. For steel castings, it is important that the mold fills quickly, but turbulent flow needs to be avoided.

- Molten steel “freezes” quickly, so the mold needs to fill rapidly from multiple directions.
- But turbulent, high velocity metal flow promotes “reoxidation” with the formation of non-metallic inclusions.
- Runners and gates have to promote high volume, low velocity flow.
- The runners and gates need to be integrated with the placement of the risers.

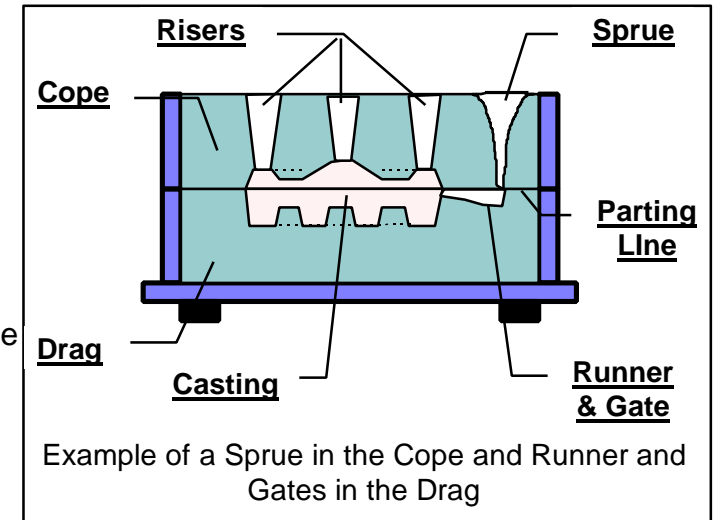

**Design Options** -- Choose a “runner/gate” design for the drag pattern that will provide high volume, low velocity flow feed into the mold from multiple directions.

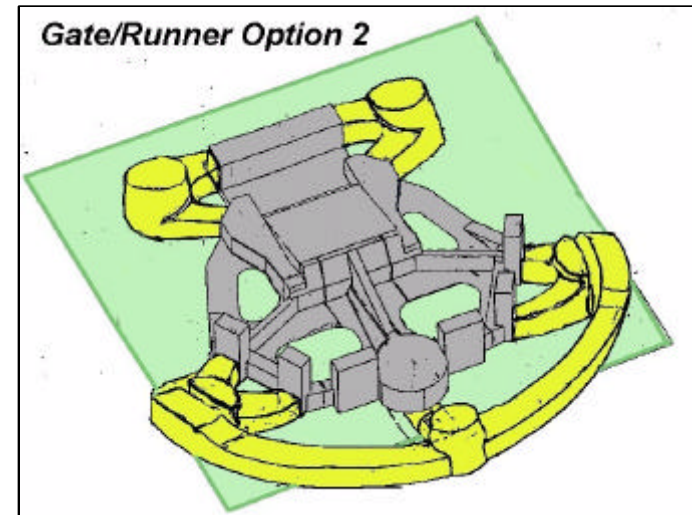
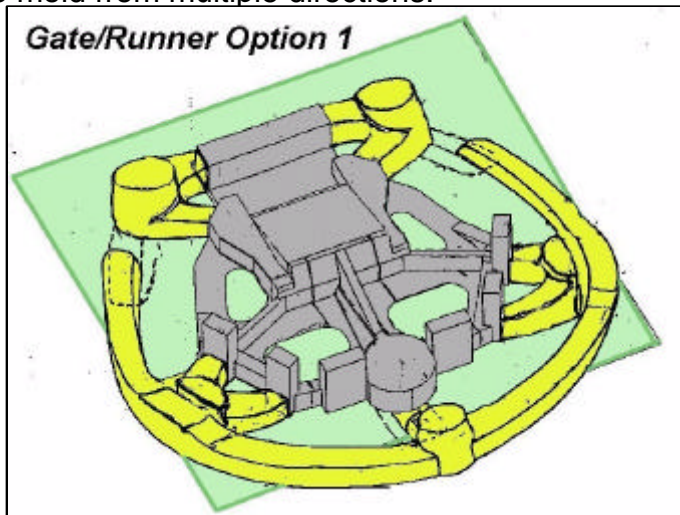

**Option 1 -**

This runner and gate system provides non-turbulent flow, high volume flow into the mold. Metal enters from many different directions with short flow paths. The system is also properly oriented with the risers.

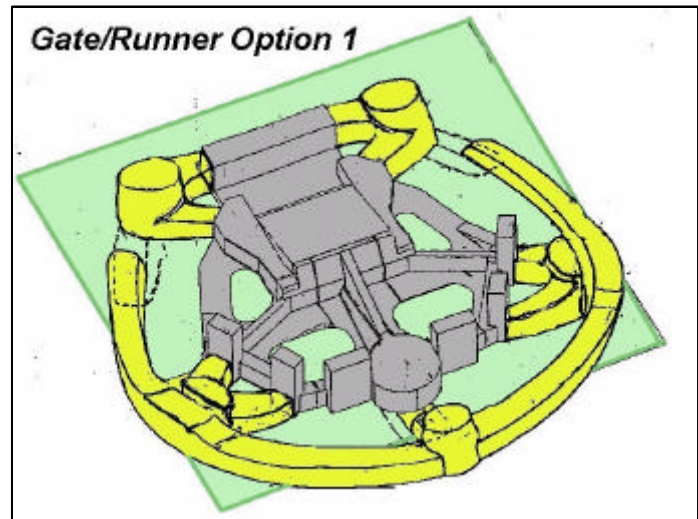

**Option 2 -**

This runner and gate system feeds into the mold from only one side. The risers on the far side have to fill through the mold. The feed will be slow and turbulent going through the casting section. Choose another option.

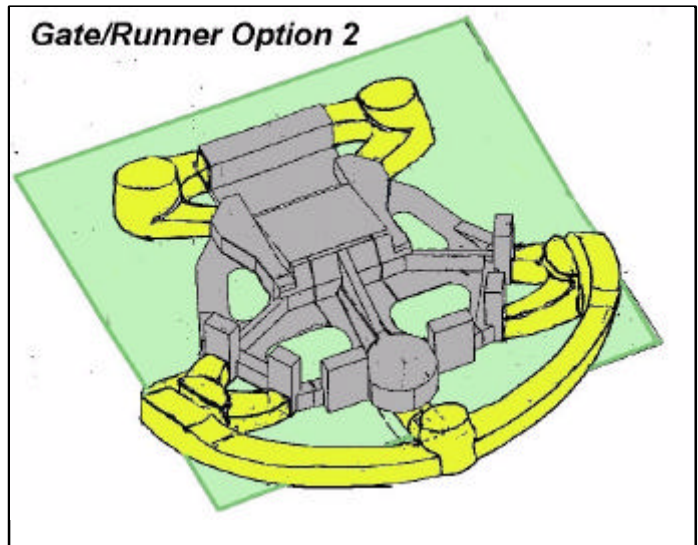

### **Final Design of Cope and Drag Patterns**

The down sprue is positioned in the cope pattern and the drag design is matched to the cope pattern. The design of the two patterns is finalized. They are then used to fabricate wooden cope and drag patterns.

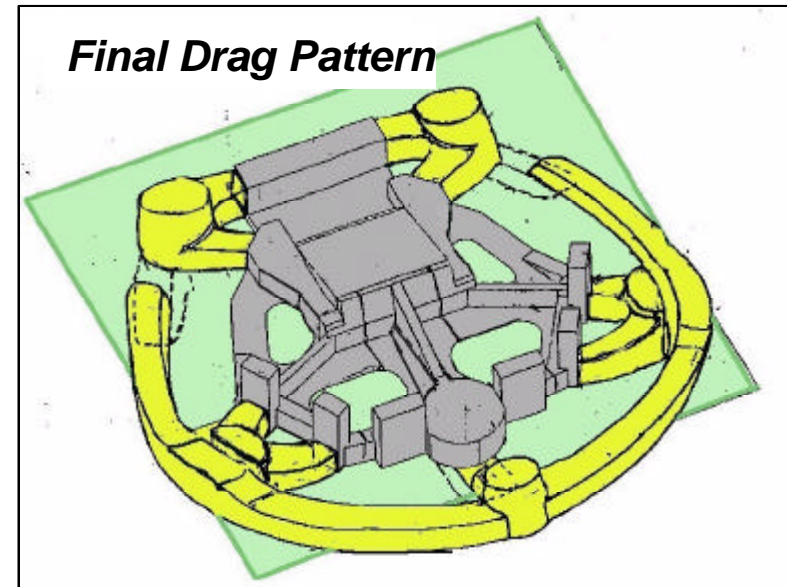
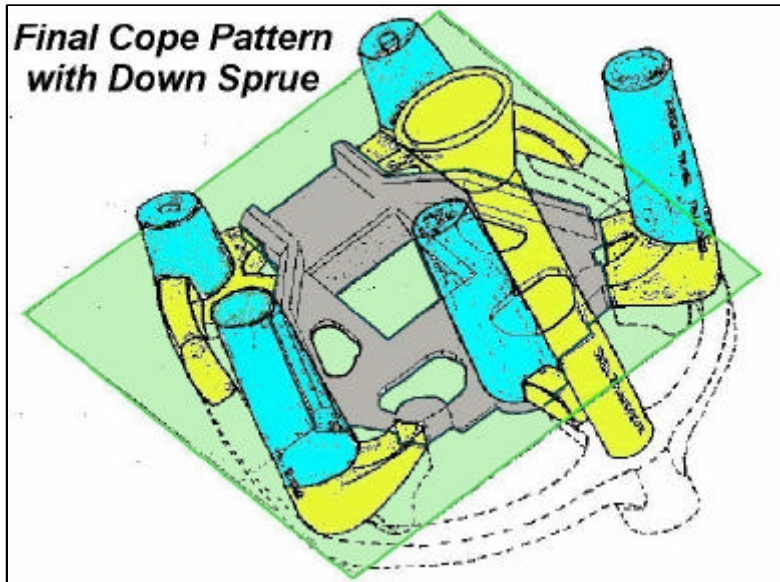



## THE FINISHED COPE AND DRAG PATTERNS

These patterns are used to form sand molds for casting the one person hitch housings in steel.

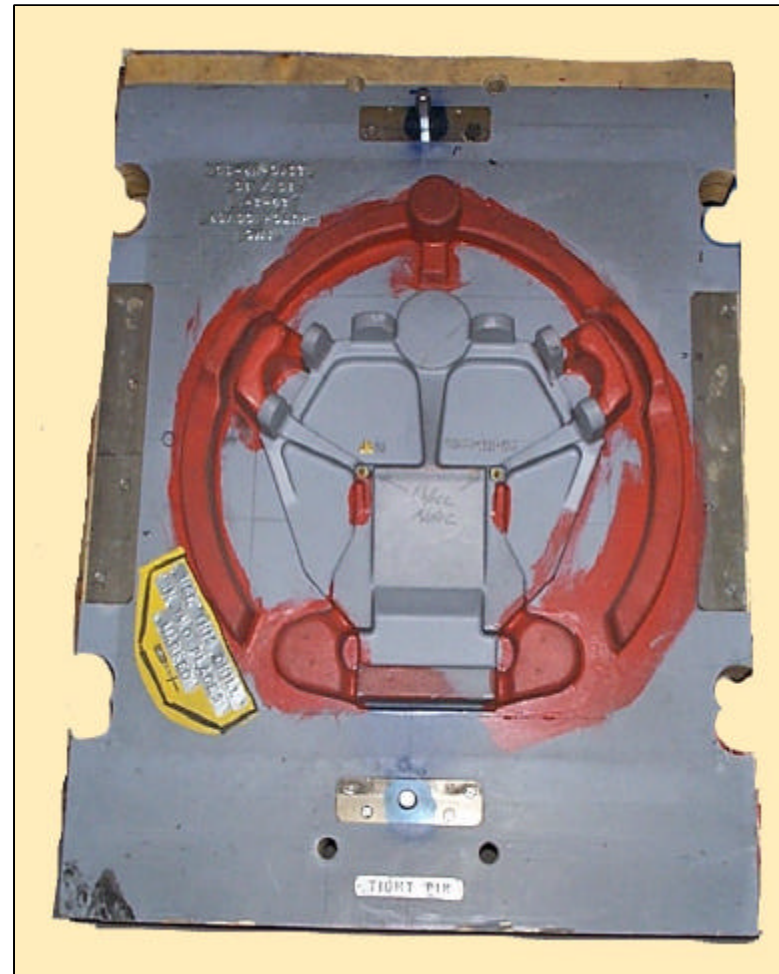
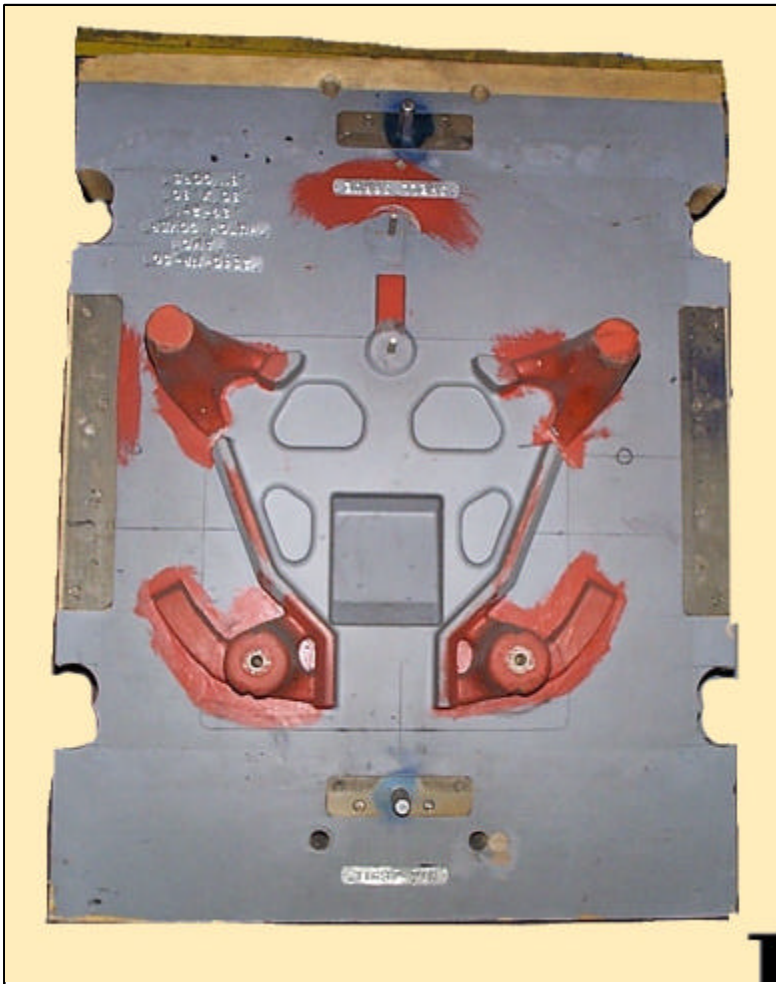

### The Finished Casting

One person hitch housings were successfully cast in steel at Pelton Casteel, Milwaukee, WI in 1998. The steel castings were sound and flaw free, based on examination by radiography and die penetrant.



## SUMMARY

A steel casting was produced that met performance and cost goals. This was accomplished through a sound understanding of casting principles and design, considering the factors of –

- Alloy Casting Properties
- Directional Solidification
- Metal Flow
- Mold and Pattern Design

By switching to a casting, cost and performance of the component were improved, compared to welded assemblies.

- A simpler design with fewer parts (10) and lower weight.
- Lower manufactured cost.
- Faster, more precise alignment/adjustment procedures during installation.
- Improved durability over the steel assembly

## **Acknowledgement**

*The metalcasting examples are a joint effort of the Steel Founder's Society of American and the American Foundrymen's Society.*

*Project funding was provided by the American Metal Casting Consortium Project, which is sponsored by the Defense Logistics Agency, Attn: DLSC-T, Ft. Belvoir, VA 22060-6221.*

*Your comments and suggestions on these metalcasting examples are welcome.*

*Updated -- June 1998*



## GLOSSARY

<b>Term</b>	<b>Definition</b>
Cope	The upper or topmost section of a flask, mold, or pattern.
Core	A preformed sand aggregate inserted in a mold to shape the interior or that part of a casting that cannot be shaped by the pattern.
Directional Solidification	The progressive freezing of the casting in an orderly fashion from a thin or chilled area of the casting, back through progressively heavier sections. Directional solidification occurs only when a deliberate temperature gradient has been established.
Down Sprue	The first channel, usually vertical, by which the molten metal enters into the mold.
Draft Angle	The angle applied to the vertical surfaces of patterns or coreboxes that allows the pattern or core to be removed or drawn. If the draft is not adequate, the pattern will cause the sand to break away from the mold as it is withdrawn.
Drag	The lower or bottom section of a mold, flask, or pattern.
Gates	The end of a runner in a mold where molten metal enters the mold cavity.
Hot Spots	Localized sections of a mold or casting where higher temperatures are maintained and where solidification will occur last without sufficient molten metal feed.
Mold	The form, made of sand, metal, or refractory material, which contains the cavity into which molten metal is poured to produce a casting of a desired shape.
Padding	The process of adding metal to a cross section of a casting wall, usually extending from a riser, to ensure adequate feed to a localized area where a shrink would occur if the added metal were not present.
Parting Line	The plane or planes along which a pattern is split or parted. It defines the separation between the cope and drag portions of a sand mold.
Pattern	A form of wood, plastic, foam, metal, or other material around which a molding material is placed

to make a mold.

Risers

A reservoir of molten metal from which casting feeds as it shrinks during solidification

Runners

The portion of the gate assembly that connects the down sprue with the gate or the riser.

Taper

A section of a casting of increasing cross-section which provides a temperature gradient and promotes directional solidification.