



A Design Study in Metal Matrix Composite Castings

***Transmission Case for the
Advanced Amphibious Assault Vehicle***

Design Study Outline

Introduction

Designing for Performance

Alloy Selection

Designing for Castability

Orientation in the Mold

Metal Flow and Thin-Wall Fill

Gating/Rigging Design

Tooling

Machining

Lessons Learned and Summary



Start the Design Study !



Acknowledgment --

*The metalcasting design studies are a joint effort of the
American Foundry Society and the Steel Founders' Society of America.*

*Project funding was provided by the American Metalcasting Consortium Project, which is sponsored by the
Defense Logistics Agency, Attn: DLSC-T, Ft. Belvoir, VA, 22060-6221*



[Return to AFS
Home Page](#)

Copyright 2001 by the American Foundry Society
All rights reserved.
Address comments to: jss@afsinc.org
Last Modified: September, 2001 by STG

***In cooperation with
Eck Industries***





A Design Study in Metal Matrix Composite Castings - AAV Transmission Case

Transmission Case - Application

The Application --

This component is the transmission case for the Advanced Amphibious Assault Vehicle (AAAV) being developed for the U.S. Marine Corps.

The AAV is a high water-speed amphibious armored personnel carrier designed to replace the current family of Marine Corps assault amphibians.

The AAV will weigh about 37 tons, be able to carry 17 combat equipped Marines and a crew of 3 over 3 ft. high waves at 25 kts. and travel over land at 45 mph.

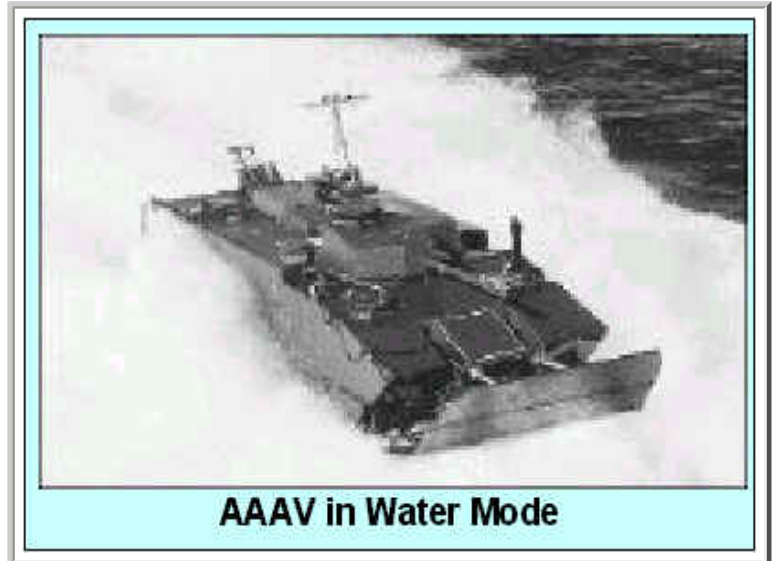

AAAV in Water Mode

The AAV provides a tactical assault capability for Marines on amphibious ships standing well offshore—even over the horizon—from the objective. The vehicle will rapidly transport the landing force over the beachhead to an objective ashore, using its water jet drive. Once ashore, the AAV will serve as a tracked infantry fighting vehicle



 Copyright 2001 by the American Foundry Society All rights reserved.
Address comments to: jss@afsinc.org
Last Modified: September, 2001 by STG
[Return to AFS Home Page](#)

[Page 1](#)

In Cooperation with 
Eck Industries



A Design Study in Metal Matrix Composite Castings - AAV Transmission Case

Transmission Case

Function and Design



Component Function and Design--

The AAV uses an Allison transmission for transmitting and gearing the power from the MTU MT883 Diesel engine (rated at 2700 hp-Water Mode and 850 hp-Land Mode) to the tracks and the water jets.

- On land the AAV has six speeds with hydrokinetic steering and equal forward and reverse speeds.
- In the water, the AAV is propelled by two water jet pumps with a total thrust of 22,794 Pounds Maximum



The transmission case has to have high stiffness and low weight to minimize load distortion and meet horsepower/ weight ratio targets.



[Back](#) [Next](#)

3



Copyright 2001 by the American Foundry Society All rights reserved.

Address comments to: jss@afsinc.org

Last Modified: September, 2001 by STG

[Return to AFS](#)
[Home Page](#)



[Page 1](#)

In Cooperation with
[Eck Industries](#)





A Design Study in Metal Matrix Composite Castings - AAV Transmission Case

Transmission Case -- Description

- The transmission case has an open box configuration with complex interior walls and extensive internal features for gear, shaft, and valve placement and alignment.
- The case has a 30" cube envelope and a 155# cast weight. Minimum wall thicknesses are on the order of 0.160".
- Extensive machining is required for mounting, alignment and mating features. The critical dimensional tolerance for as-cast surfaces is +/- 0.04 inches.
- The transmission case was designed from the start as a casting; a component of this complexity could not be produced reliably and economically by welding

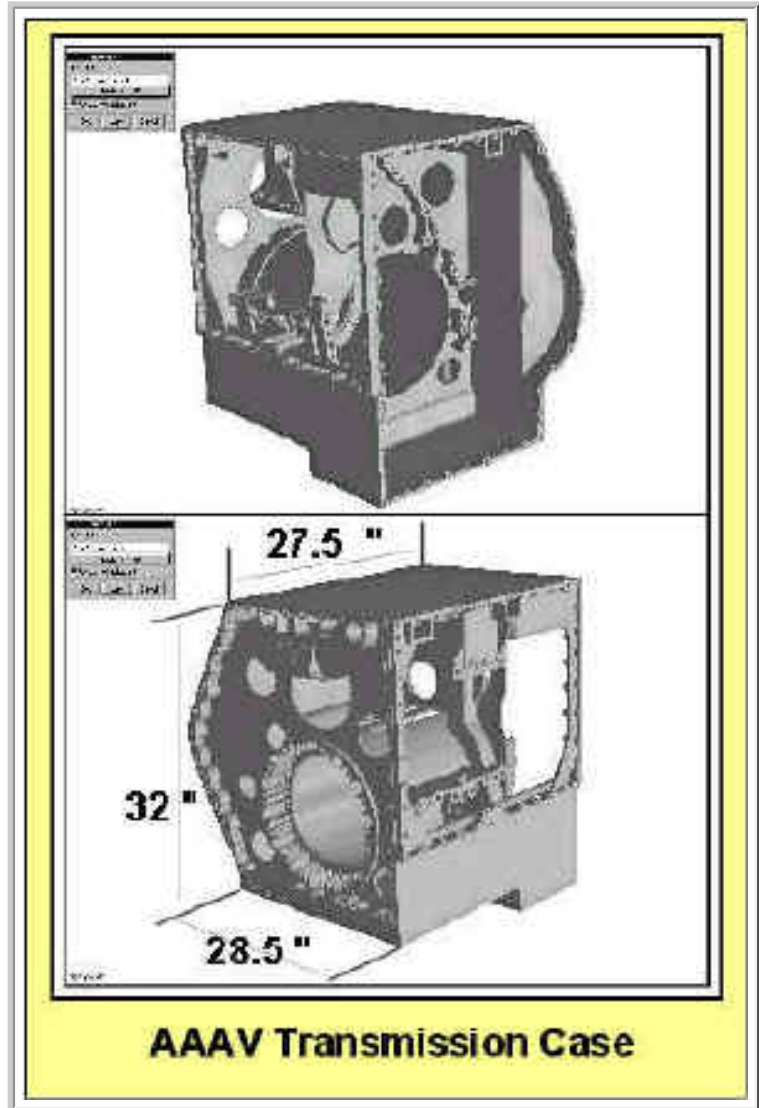

[Back](#) [Next](#)

4



Copyright 2001 by the American Foundry Society. All rights reserved.

Address comments to: jss@afsinc.org

Last Modified: August, 2001 by STG

[Return to AFS Home Page](#)



[Page 1](#)

In Cooperation with
[Eck Industries](#)





A Design Study in Metal Matrix Composite Castings - AAV Transmission Case

The Casting Design Issues

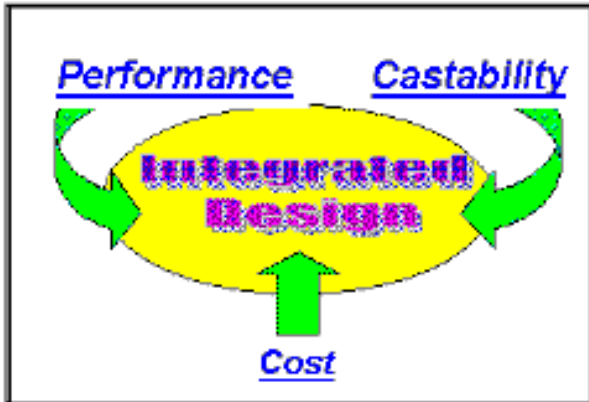

The Casting Design Approach -- The casting design engineers at the Eck Industries chose gravity casting with "no-bake" sand molds and cores. The engineers had three imperatives for an integrated casting design.

- *Design for Performance*
- *Design for Castability/Manufacturability*
- *Design for Cost*

Critical Casting Design Issues --The requirements for performance, castability/manufacturability, and cost are closely interconnected. Four casting design issues played a major role in meeting the three design imperatives

- Select the [alloy composition](#) to meet the mechanical property requirement.
- Develop the [mold design](#) to optimize metal flow and insure soundness
- Design the [gating system](#) to produce sound castings and maximize casting metal yield.
- Develop a cost-effective [machining process](#) for the transmission case.



[Back](#) [Next](#)

5



[Return to AFS Home Page](#)

Copyright 2001 by the American Foundry Society All rights reserved.

Address comments to: jss@afsinc.org

Last Modified: August, 2001 by STG



[Page 1](#)

In Cooperation with
[Eck Industries](#)





A Design Study in Metal Matrix Composite Castings - AAV Transmission Case

Metal Matrix Composite Alloy Selection

- Aluminum reinforced with silicon carbide (SiC) particulate has superior elastic modulus, strength, and wear resistance compared to unreinforced aluminum alloy.
- In addition the SiC reinforced aluminum has enhanced thermal conductivity and a reduced coefficient of thermal expansion.
- With higher modulus and strength in the aluminum MMC, the wall thickness of a given component can be reduced and weight saved, while still meeting required stiffness and strength targets.

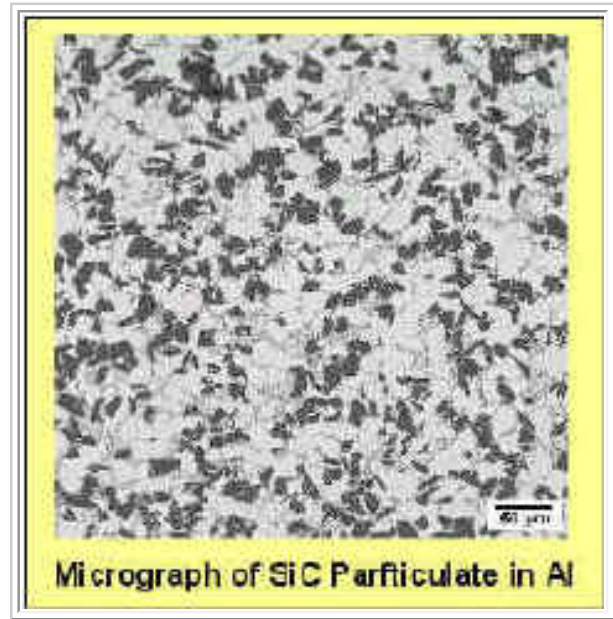

The key question is -- How much silicon carbide particulate must be added to the aluminum to achieve the desired mechanical properties?



[Back](#) [Next](#)

7



[Return to AFS Home Page](#)

Copyright 2001 by the American Foundry Society All rights reserved.

Address comments to: jss@afsinc.org

Last Modified: August, 2001 by STG



[Page 1](#)

In Cooperation with
[Eck Industries](#)





A Design Study in Metal Matrix Composite Castings - AAV Transmission Case

Material Selection Challenge

- The combined requirement for high stiffness and low weight in the transmission case cannot be met with conventional aluminum or iron casting alloys.
- A metal matrix composite (MMC) alloy, specifically, aluminum with silicon carbide particulate, offers the best combination of high modulus, low density and castability



**Aluminum MMC Brake Rotor
for Chrysler Prowler**

Aluminum MMC castings are being commercialy used for high performance automotive brakes.

The challenge in manufacturing the transmission case was to select the best alloy and to design the casting features to meet the performance and production targets, specifically --

- *Achieving the desired stiffness and weight reduction*
- *Designing the casting and the rigging system to insure soundness and to meet the required dimensional tolerances*
- *Developing and using cost-effective machining procedures.*



[Back](#) [Next](#)

6



Copyright 2001 by the American Foundry Society All rights reserved.

Address comments to: jss@afsinc.org

Last Modified: August, 2001 by STG

[Return to AFS
Home Page](#)



[Page 1](#)

*In Cooperation with
[Eck Industries](#)*





A Design Study in Metal Matrix Composite Castings - AAV Transmission Case

SiC Additions to the Aluminum Alloy

- The baseline aluminum alloy for this application is C 355 with a T6 temper.
(The C355 alloy has a composition of 4.5%-5.5% Si, 1.0%-1.5% Cu, and 0.40%-0.60% Mg)
- Silicon carbide particulate can be added to aluminum alloy (A 359) at 10vol% and 20vol% levels.

Alloy		C355 -T6	A 359 with 10% SiC	A 359 with 20% SiC
Performance	Target			
<i>Elastic Modulus (MSI)</i>	>12.5	10.2	12.5	14.3
<i>Ultimate Tensile Strength (ksi)</i>	>40	35	49	50
<i>Tensile Yield Strength (ksi)</i>	>30	25	44	47
<i>Hardness (Rockwell HRB)</i>	>55	80	73	77
<i>Density (lb/in³)</i>	NA	0.0980	0.0979	0.0999
Castability				
<i>Relative Fluidity (compared to C355)</i>	= or >85%	100%	93%	85%

The table above lists the performance and castability properties of 10% and 20% silicon carbide aluminum composite alloys, compared to C355 alloy



[Back](#) [Next](#)

8

[Return to AFS Home Page](#)

Copyright 2001 by the American Foundry Society All rights reserved.
 Address comments to: jss@afsinc.org
 Last Modified: September, 2001 by STG

[Page 1](#)

In Cooperation with
[Eck Industries](#)





A Design Study in Metal Matrix Composite Castings - AAV Transmission Case

Choose an SiC Addition Level

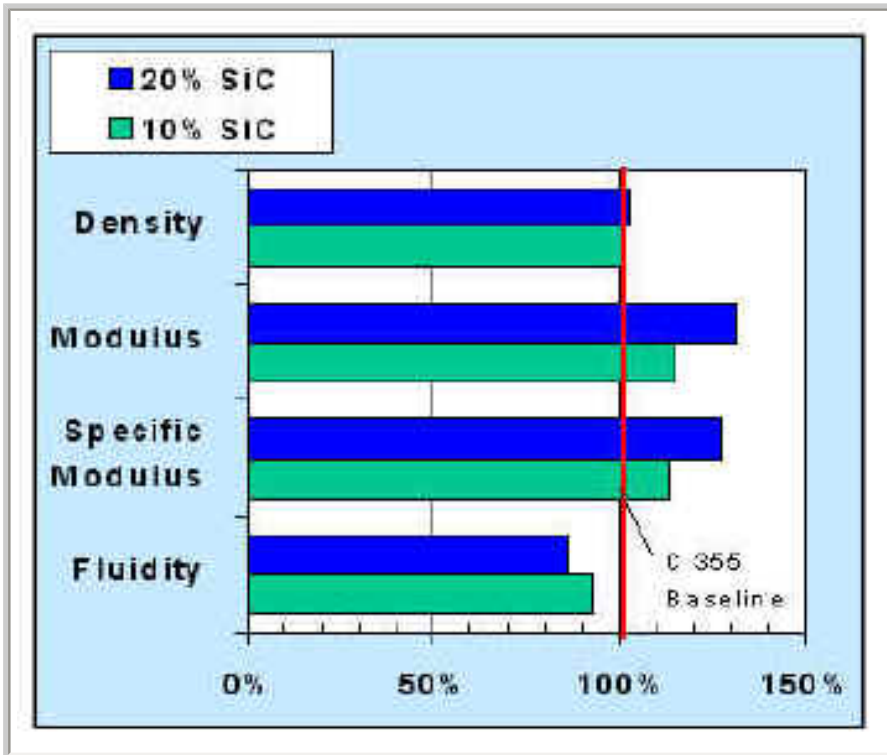

- The chart to the left compares the properties of 10% and 20% SiC additions to aluminum, normalized to the C 355 alloy at the 100% level.
- The SiC addition level of choice should have the maximum specific modulus (ratio of modulus to density) to meet the stiffness requirement while minimizing the weight
- In addition, the alloy should meet or exceed the fluidity requirement (85% of the C 355 level) to insure that the molten alloy will fill the mold without flaws.

Which SiC addition (10 vol% or 20 vol%) best meets the requirement for high modulus, low density, and sufficient fluidity?



[Back](#)

[Return to AFS Home Page](#)

Copyright 2001 by the American Foundry Society. All rights reserved.
 Address comments to: jss@afsinc.org
 Last Modified: September, 2001 by STG

[Page 1](#)

In Cooperation with
[Eck Industries](#)





A Design Study in Metal Matrix Composite Castings - AAV Transmission Case

10% SiC Addition to Aluminum

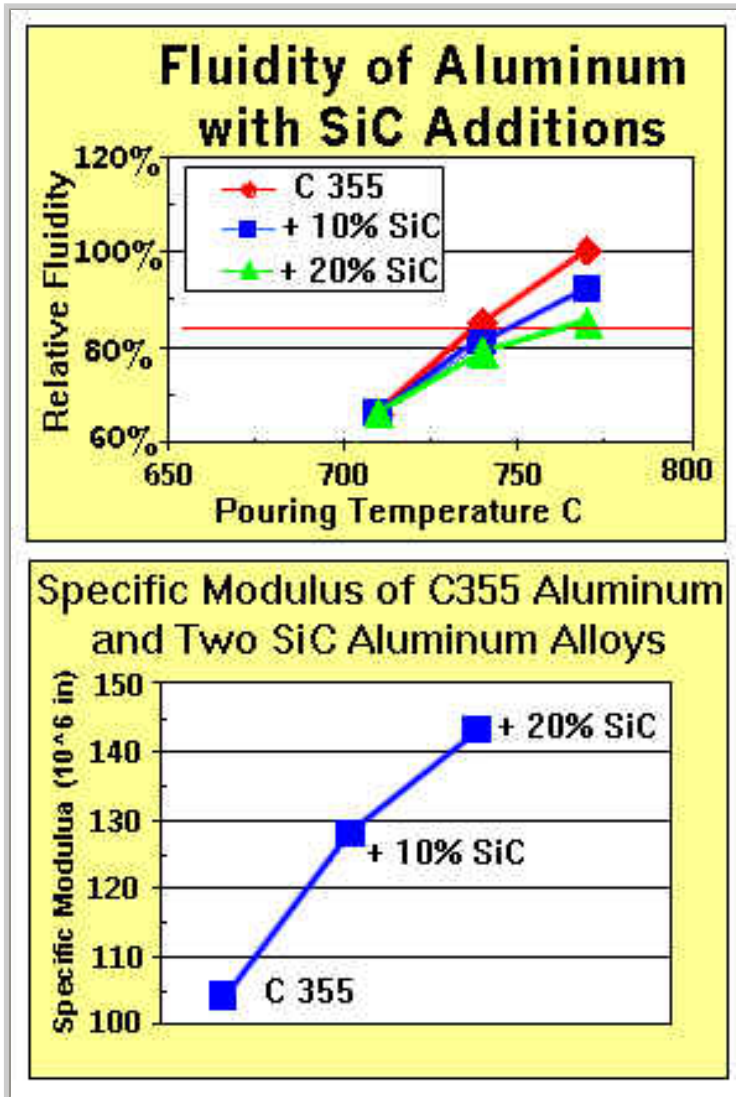

- The aluminum with 10% SiC addition meets the minimum requirements for modulus and strength, compared to the unreinforced C 355-T6.
- The fluidity of the aluminum with 10% SiC addition exceed the minimum fluidity requirements at the 775C pouring temperature.
 - *It is approximately 10% more fluid than the Al-20% SiC alloy.*
- But the specific modulus (*modulus divided by the density*) for the 10% SiC addition is 12% lower than the specific modulus for the 20% SiC addition (12.5×10^6 vs 14.3×10^6 in)

[Go back to the alloy page and select another level of SiC addition](#)



[Back](#)

10



[Return to AFS Home Page](#)

Copyright 2001 by the American Foundry Society All rights reserved.
Address comments to: jss@afsinc.org
Last Modified: August, 2001 by STG



[Page 1](#)

In Cooperation with
[Eck Industries](#)





A Design Study in Metal Matrix Composite Castings - AAV Transmission Case

20% SiC Addition to Aluminum

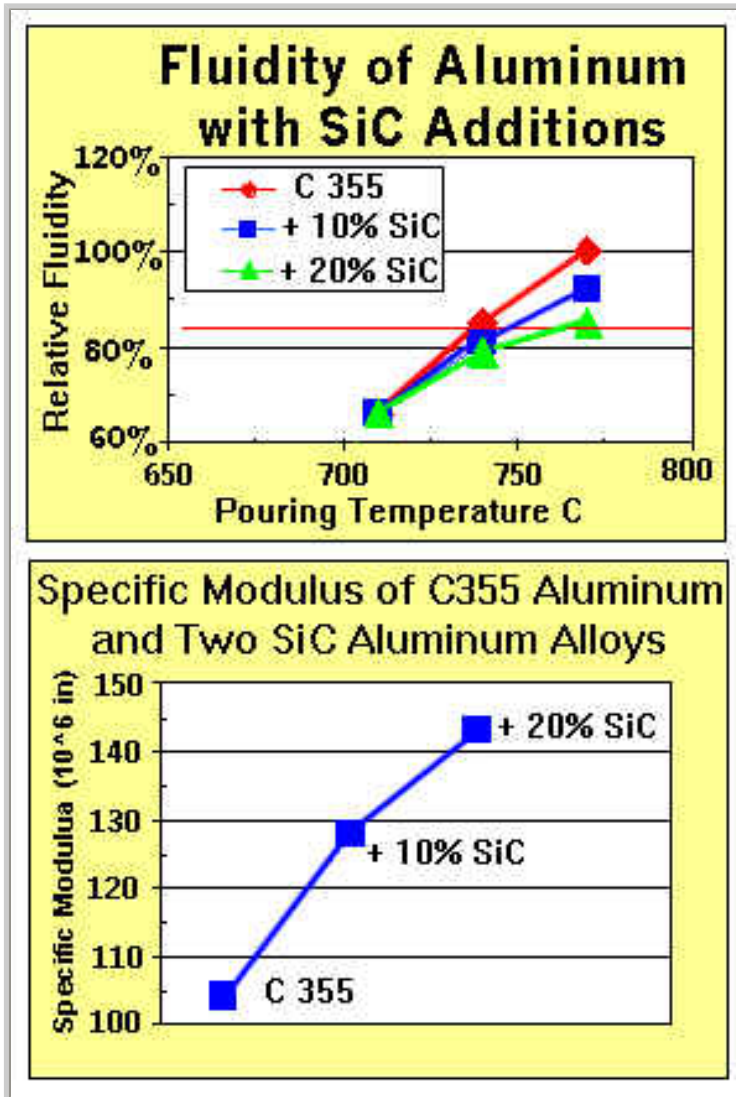

- The aluminum with 20% SiC addition exceeds the minimum requirements for modulus and strength, compared to the unreinforced C 355-T6.
- The fluidity of the aluminum with 20% SiC addition meets the minimum fluidity requirements at the 775C pouring temperature.
- The specific modulus (*modulus divided by the density*) for the 20% SiC addition has the highest value (14.3×10^6 in) compared to values for baseline C355 and the 10% SiC-aluminum alloy.

[Go to the Next Design Issue!](#)



[Back](#) [Next](#)

11



[Return to AFS Home Page](#)

Copyright 2001 by the American Foundry Society. All rights reserved.
Address comments to: jss@afsinc.org
Last Modified: August, 2001 by STG



[Page 1](#)

In Cooperation with
[Eck Industries](#)





A Design Study in Metal Matrix Composite Castings - AAV Transmission Case

Mold Design and Part Orientation

In mold design for gravity casting, the orientation of the part in the mold is an important factor in producing a sound metal matrix composite casting.

- Casting defects, when they occur in SiC- aluminum, favor the cope or upper surface of gravity castings.
- Primary surfaces should be designed so that they are molded in the drag or the lower section of the casting.
- Additional machine stock should be allowed on upper surfaces so that surface defects can be removed if necessary.

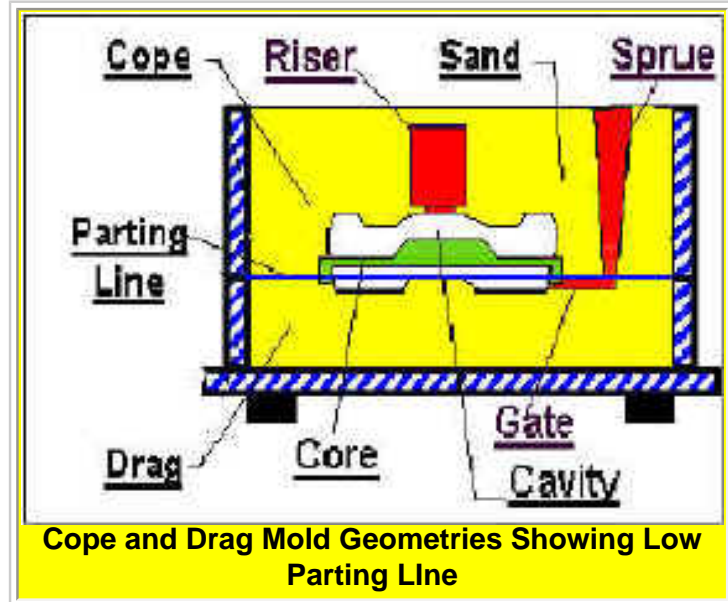

- **Placement of the parting line is critical in casting SiC-aluminum.**
- **The metal feed runners and gates are in the top section of the lower drag mold. The molten metal should enter at the bottom of the mold cavity, minimizing metal fall.**
- **Therefore, the mold cavity should sit high in the mold, with the parting line at the bottom of the mold cavity.**



[Back](#) [Next](#)

12



[Return to AFS Home Page](#)

Copyright 2001 by the American Foundry Society All rights reserved.

Address comments to: jss@afsinc.org

Last Modified: August, 2001 by STG



[Page 1](#)

In Cooperation with
[Eck Industries](#)





A Design Study in Metal Matrix Composite Castings - AAV Transmission Case

Mold Design

The transmission case is gravity cast in a no-bake sand mold with multiple, complex cores. There are two critical features in the transmission case --

- *The spline section at the bottom of the internal barrel.*
- *The flat base plate of the transmission case which requires numerous bolt holes for attaching the fluid valves.*

Both of these features are critical mating surfaces; they required extensive machining and need to be free of voids and defects.

→ *The spline is the more critical feature.*

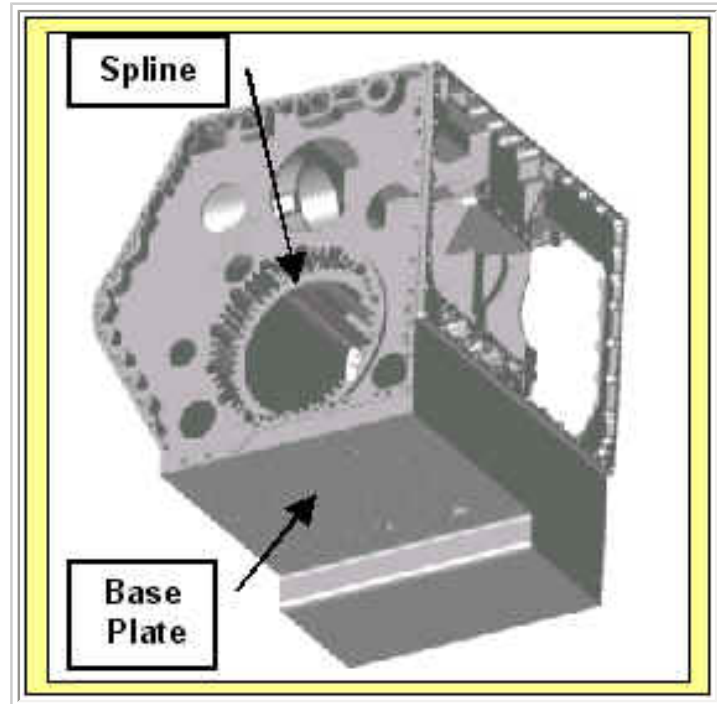

A key casting design issue is how to orient the component so that the most critical feature is in the bottom of the mold cavity.



[Back](#) [Next](#)

13



Copyright 2001 by the American Foundry Society All rights reserved.
Address comments to: jss@afsinc.org
Last Modified: August, 2001 by STG



[Page 1](#)

In Cooperation with
[Eck Industries](#)





A Design Study in Metal Matrix Composite Castings - AAV Transmission Case

Mold Design

Considering the issues of parting line placement and mold orientation, three mold design options were considered.

-- [Option A](#) - Low Parting line with the Base Plate Down in the Drag

-- [Option B](#) - Low Parting Line with Spline Section Down in the Drag

-- [Option C](#) - Middle Level Parting Line with Spline Section Down in the Drag.

**Choose the mold design
([Option A](#), [Option B](#) or [Option C](#))**

which places the critical feature in the lower section of the mold and minimizes metal fall.



**Option A -- Low Parting Line,
Base Plate Down**



**Option B -- Low Parting Line,
Spline Section Down**



**Option C -- Middle Parting Line,
Spline Section Down**



[Back](#)

14



[Return to AFS
Home Page](#)

Copyright 2001 by the American Foundry Society All rights reserved.
Address comments to: jss@afsinc.org
Last Modified: August, 2001 by STG



[Page 1](#)

In Cooperation with
[Eck Industries](#)





A Design Study in Metal Matrix Composite Castings - AAV Transmission Case

Option A - Low Parting Line with Base Plate Down

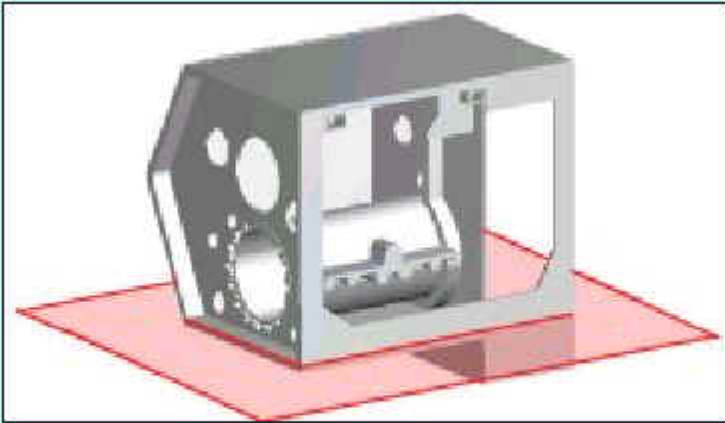

Option A -- Low Parting Line,
Base Plate in the Cope

In Option A, the parting line is low on the mold cavity. This will give smooth nonturbulent metal flow into the mold cavity and will minimize bubbles and oxide particulates.

This mold design has one critical shortcoming --

- *The base plate is in the drag and the more critical spline section is in the vertical wall with a risk that voids and/or oxides will form in that feature.*

For this reason, Option A is not the best mold design.

[Go Back to the Options Page](#)



[Back](#)

15



[Return to AFS
Home Page](#)

Copyright 2001 by the American Foundry Society All rights reserved.

Address comments to: jss@afsinc.org

Last Modified: August, 2001 by STG



[Page 1](#)

In Cooperation with
[Eck Industries](#)





A Design Study in Metal Matrix Composite Castings - AAV Transmission Case

Option B - Low Parting Line with Spline Down

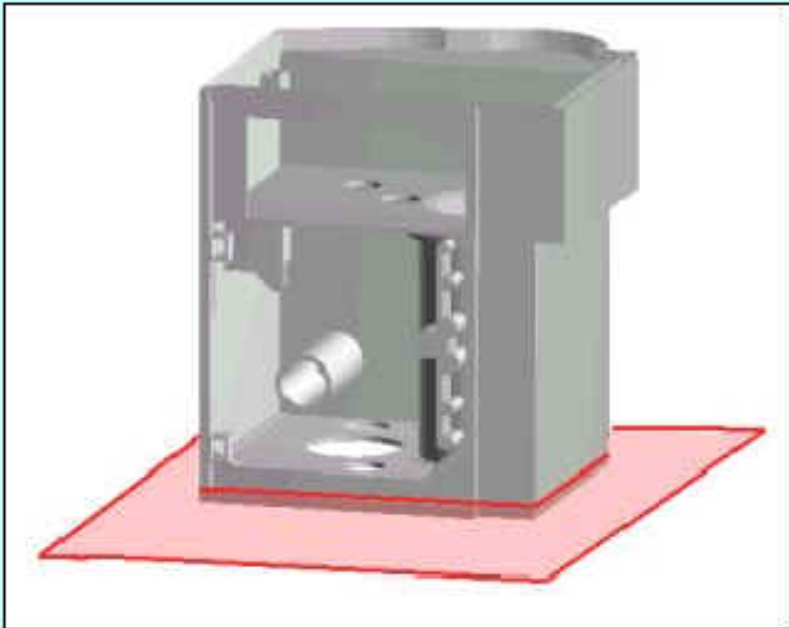

In Option B, the spline section is oriented down in the drag (the lower mold cavity). This orientation minimizes the risk of flaw segregation in the spline feature.

The parting line is low in the mold cavity. This will give smooth nonturbulent metal flow into the mold cavity and will minimize bubbles and oxide particulates.

***For these reasons,
Option B is the best
mold design.***

**Option B -- Low Parting Line,
with Spline in the Drag**

[Go to the Next Design Issue](#)



[Back](#) [Next](#)

16



Copyright 2001 by the American Foundry Society All rights reserved.

Address comments to: jss@afsinc.org

Last Modified: August, 2001 by STG

[Return to AFS
Home Page](#)



[Page 1](#)

*In Cooperation with
[Eck Industries](#)*





A Design Study in Metal Matrix Composite Castings - AAV Transmission Case

Casting Flow and Wall Fill

When gravity casting SiC-aluminum MMC alloys, the foundry engineer cannot rely on excess superheat or high metal velocity to fill thin walls and extended features.

- ***Excess superheat will result in aluminum carbide formation in the melt which will reduce mechanical properties.***
- ***High metal velocities result in high levels of casting defects.***

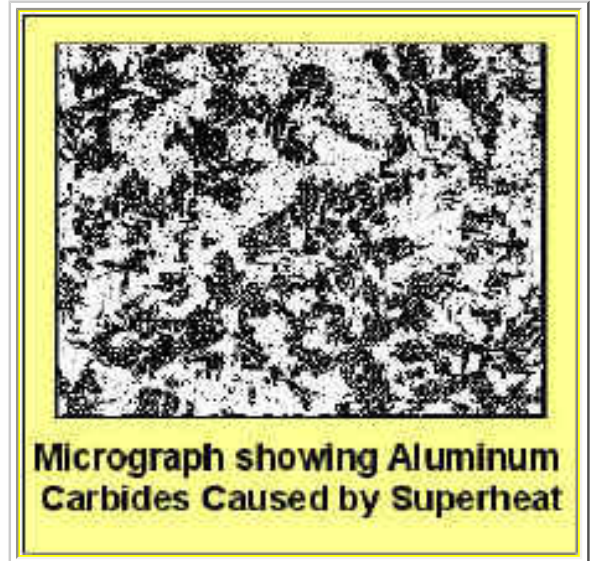

The casting engineer should review the casting design for thin wall sections and long runs and consider where and how to thicken critical wall features to eliminate misruns.



[Back](#) [Next](#)



[Return to AFS Home Page](#)

Copyright 2001 by the American Foundry Society All rights reserved.
Address comments to: jss@afsinc.org
Last Modified: August, 2001 by STG



[Page 1](#)

In Cooperation with
Eck Industries





A Design Study in Metal Matrix Composite Castings - AAVV Transmission Case

Design of the Barrel Wall



First Casting with Misrun in Wall

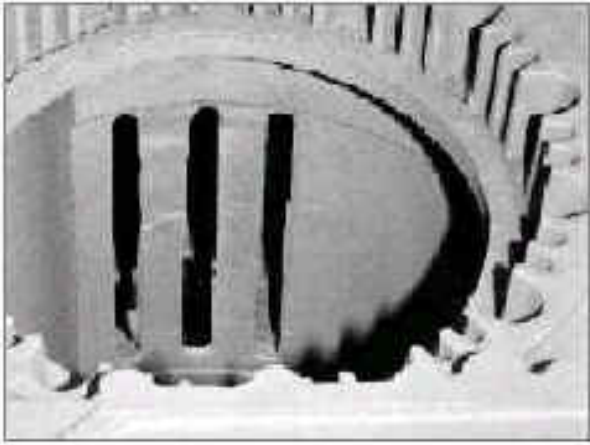

Redesigned Wall with no Flaws

- The interior barrel section of the transmission case was originally designed with a thickness of 160 mils.
 - The barrel has a length of 20 inches.
- The first casting of the barrel with the 160 mil wall thickness had poor fill and misruns in several webs between slots in the interior wall of the barrel
- The wall thickness was increased to 240 mils, an increase of 50%. This promoted uniform flow and good fill.
- New castings had no flaws or misruns in the barrel wall.



[Back](#) [Next](#)



Copyright 2001 by the American Foundry Society All rights reserved.

Address comments to: jss@afsinc.org

Last Modified: August, 2001 by STG

[Return to AFS Home Page](#)



[Page 1](#)

In Cooperation with
[Eck Industries](#)





A Design Study in Metal Matrix Composite Castings - AAV Transmission Case

Rigging Design

Most rigging systems for gravity castings develop high levels of turbulence in the down sprue. Conventional gating design allows little time to "quiet" the metal before it enters the mold.

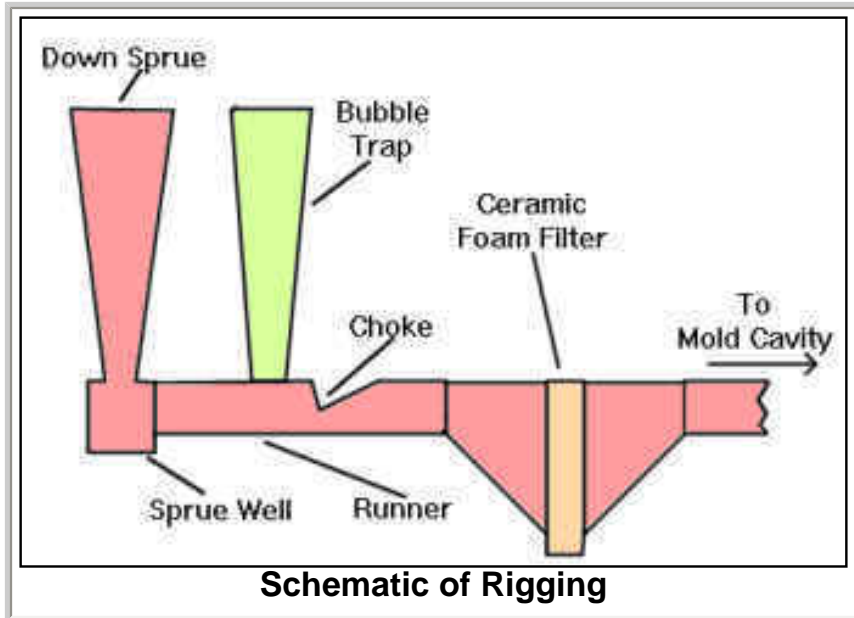

Gating/rigging systems for metal matrix composite casting are modified with --

- >> Bubble traps to capture bubbles that develop in the down sprue.
- >> Chokes to control the velocity of the metal flow.
- >> Ceramic filters to block oxide particulates that form in turbulent sections



[Back](#) [Next](#)

20



[Return to AFS Home Page](#)

Copyright 2001 by the American Foundry Society All rights reserved.
Address comments to: jss@afsinc.org
Last Modified: September, 2001 by STG



[Page 1](#)

In Cooperation with
[Eck Industries](#)





A Design Study in Metal Matrix Composite Castings - AAV Transmission Case

Rigging and Gating Design

The transmission case is cast with the barrel in a vertical orientation. The mold has two down sprues which feed into runners and ingates. The ingates must provide sufficient metal flow without excessive velocity or turbulence.

>> *Multiple gates are required to provide complete flow into thin walls.*

Two different gating designs were considered and are shown in the drawing to the right --

- [Option A](#) - Three gates on each side.
- [Option B](#) - Five gates on each side.

**Choose the gating system
([Option A](#) or [Option B](#))
which provides the best metal flow
into the thin walls.**

Option A -- Three Ingates on a Side

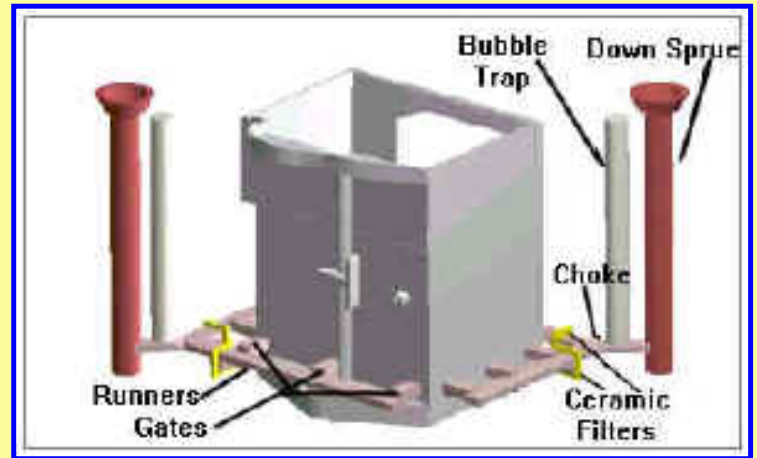

Option B - Five Ingates on a Side

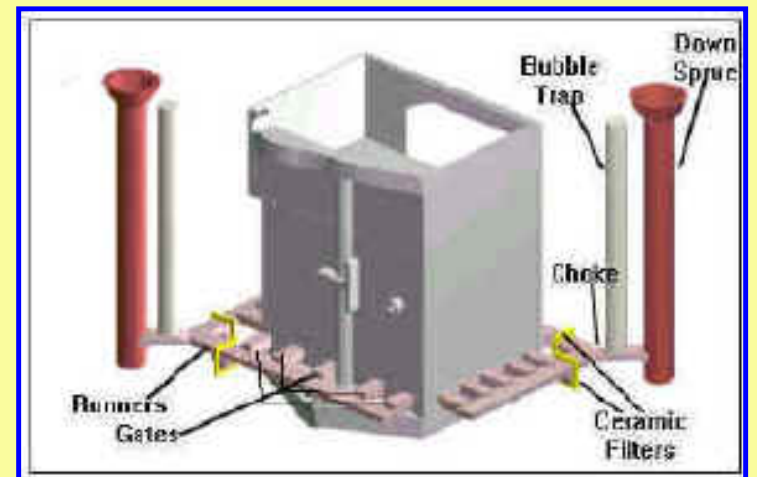

[Back](#)

21



Copyright 2001 by the American Foundry Society All rights reserved.
Address comments to: jss@afsinc.org
Last Modified: September, 2001 by STG



[Page 1](#)

In Cooperation with
[Eck Industries](#)





A Design Study in Metal Matrix Composite Castings - AAV Transmission Case

Option A - Three Ingates on a Side

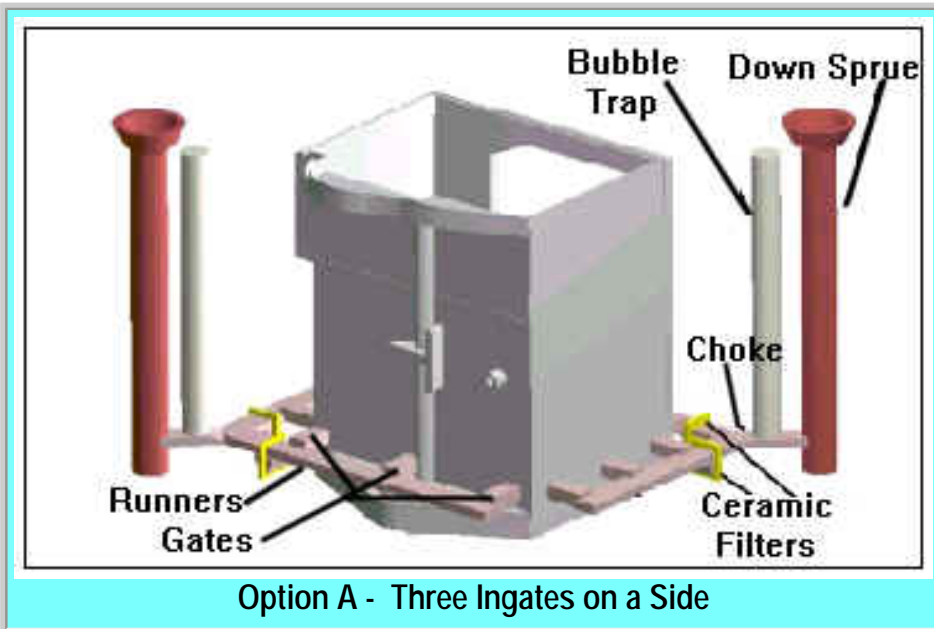

In Option A, the gating system consists of three ingates feeding metal into each side of the mold cavity

This gating approach is not good, because it will --

- *provide insufficient and slow flow into the mold cavity.*
- *May cause misruns and flaws in the casting.*

Option A is not the preferred gating system design.
[Go Back to the Options Page](#)



[Back](#)

22



[Return to AFS Home Page](#)

Copyright 2001 by the American Foundry Society All rights reserved.
 Address comments to: jss@afsinc.org
 Last Modified: August, 2001 by STG



[Page 1](#)

In Cooperation with
[Eck Industries](#)





A Design Study in Metal Matrix Composite Castings - AAV Transmission Case

Option B - Five Ingates on a Side

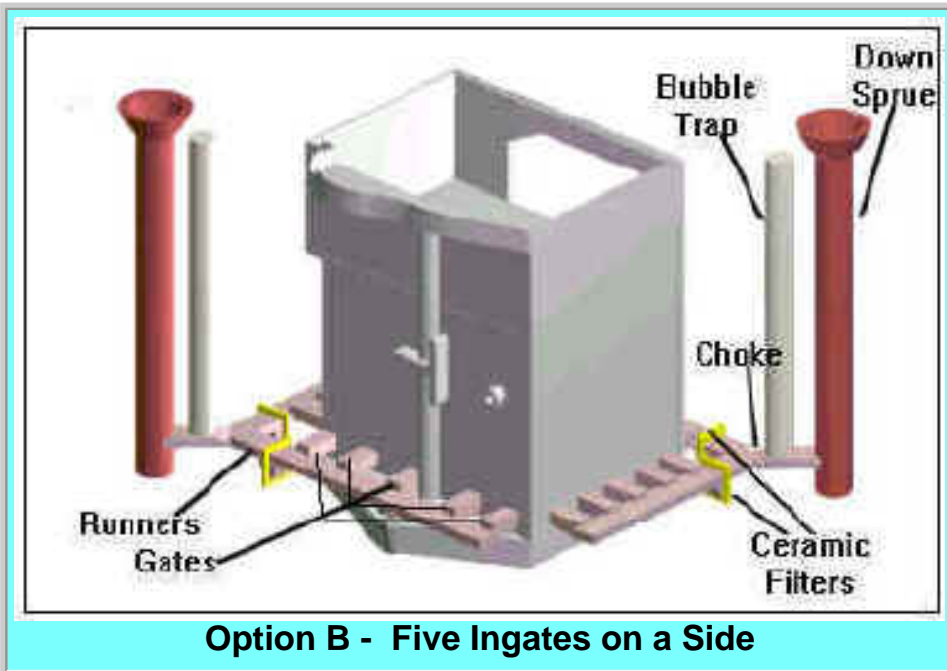

In Option B, the gating system consists of five ingates feeding metal into each side of the mold cavity

This gating approach will --

- *provide smooth and even flow into all the thin wall sections without excessive turbulence.*
- *Minimize the possibility of misruns and defects in the casting.*

Option B is the preferred gating system design.

[Go to the Next Design Issue](#)



[Back](#) [Next](#)

23



Copyright 2001 by the American Foundry Society All rights reserved.

Address comments to: jss@afsinc.org

Last Modified: August, 2001 by STG

[Return to AFS Home Page](#)



[Page 1](#)

In Cooperation with
[Eck Industries](#)





A Design Study in Metal Matrix Composite Castings - AAV Transmission Case

Patterns for the Transmission Case



Drag Pattern



Cope Pattern

- The patterns for cope, drag, and cores were CMC machined directly from the CAD model.
- Patterns were cut in mahogany wood for strength, finish, and cost effectiveness.
- The photo on the left shows the pattern for the bottom/drag mold highlighting the spline feature and the runners and gates.
- The photo on the right shows the pattern for the top/cope mold showing the inset that forms the wall edge.



[Back](#) [Next](#)

24



Copyright 2001 by the American Foundry Society All rights reserved.

Address comments to: jss@afsinc.org

Last Modified: September, 2001 by STG

[Return to AFS Home Page](#)



[Page 1](#)

In Cooperation with
[Eck Industries](#)





A Design Study in Metal Matrix Composite Castings - AAV Transmission Case

Core Assembly for the Transmission Case



Drag Mold



Interior Cores (Partial Assembly)

The complexity of the transmission case with its internal walls, flanges, and mounting features, required a complex core assembly.

- The core assembly consisted of over 30 pieces produced in no-bake sand in mahogany core boxes.

By using a multi-piece core assembly for both interior and exterior features, the transmission case was produced with zero-draft features.



[Back](#) [Next](#)



Copyright 2001 by the American Foundry Society All rights reserved.

Address comments to: jss@afsinc.org

Last Modified: August, 2001 by STG

[Return to AFS Home Page](#)



[Page 1](#)

In Cooperation with
[Eck Industries](#)





A Design Study in Metal Matrix Composite Castings - AAV Transmission Case

Machining

The machining of the transmission case was extensive --

- *Milling of faces and mating surfaces.*
- *Boring of access holes.*
- *Drilling and tapping of screw holes.*

The transmission case was machined by Schwartz Industries of Warren, MI.

- *Diamond tooling was used for face milling.*
- *Proprietary diamond tipped carbide tools were used boring and drilling.*
- *Solid carbide roll form taps were used for tapping the M8, M10, and M14 holes.*
- *A total of 41 unique tools were required to machine this casting.*
- *The machining engineer estimates that the part can be machined with only a 110% increase in machining time, compared to standard aluminum.*



As-Cast Case

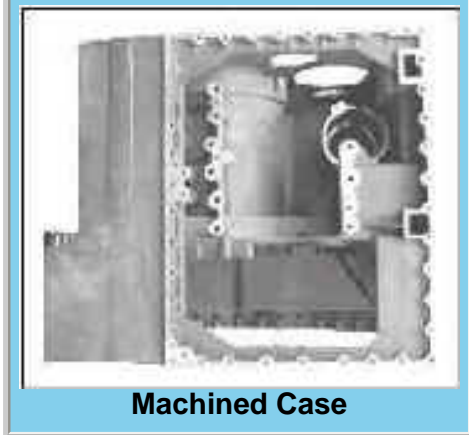

Machined Case



[Back](#) [Next](#)

26



Copyright 2001 by the American Foundry Society All rights reserved.

Address comments to: jss@afsinc.org

Last Modified: September, 2001 by STG

[Return to AFS Home Page](#)



[Page 1](#)

In Cooperation with
[Eck Industries](#)





A Design Study in Metal Matrix Composite Castings - AAV Transmission Case

Lessons Learned

Eck Industries has produced three (3) transmission cases for prototype evaluation by the AAV prime vendor, General Dynamics.

The production of the transmission case illustrates --

- The successful casting in no-bake sand of a large, extremely complex, thin wall component in aluminum-SiC composite.
- The use of polycrystalline diamond tools and specialized tool geometry kept the machining costs of the composite within the defined cost envelope.
- A 10% weight savings over the original 355 aluminum alloy design, because the higher modulus of the Al-SiC composite permits thinner walls
- This was a prototype development study and additional material and machining costs were justified in terms of performance benefits.

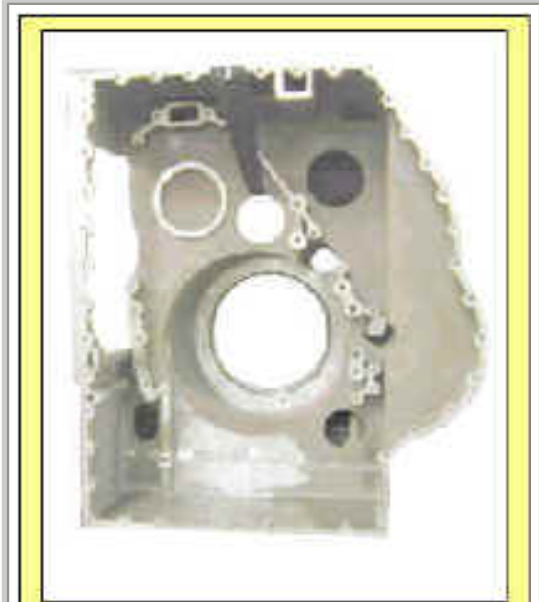

Machined Transmission Case



Mold Assembly



[Back](#) [Next](#)

27



Copyright 2001 by the American Foundry Society. All rights reserved.

Address comments to: jss@afsinc.org

Last Modified: September, 2001 by STG

[Return to AFS Home Page](#)



[Page 1](#)

In Cooperation with
[Eck Industries](#)





Summary

AAAV Transmission Case

The transmission case for the U.S. Marine Advanced Amphibious Assault Vehicle was produced by Eck Industries as a SiC-reinforced aluminum gravity sand casting with a 10% weight savings.



For further information on the design and production of this and other aluminum castings, contact **Dave Weiss** at **Eck Industries**

Phone-- 920-682-4618, FAX -- 920-862-9298 E-mail -- dweiss@eckindustries.com

Web Site = <http://www.eckindustries.com>

Acknowledgment --

The metalcasting design studies are a joint effort of the American Foundry Society and the Steel Founders' Society of America.

Project funding was provided by the American Metalcasting Consortium Project, which is sponsored by the Defense Logistics Agency, Attn: DLSC-T, Ft. Belvoir, VA 22060-6221



**The
End**

[Back One](#)

28



[Return to AFS
Home Page](#)

Copyright 2001 by the American Foundry Society,
All rights reserved.

Address comments to: jss@afsinc.org

Last Modified: September, 2001 by STG



[Page 1](#)

In Cooperation with
Eck Industries





A Design Study in Metal Matrix Composite Castings - AAV Transmission Case

Option C - Middle Parting Line with Spline Down

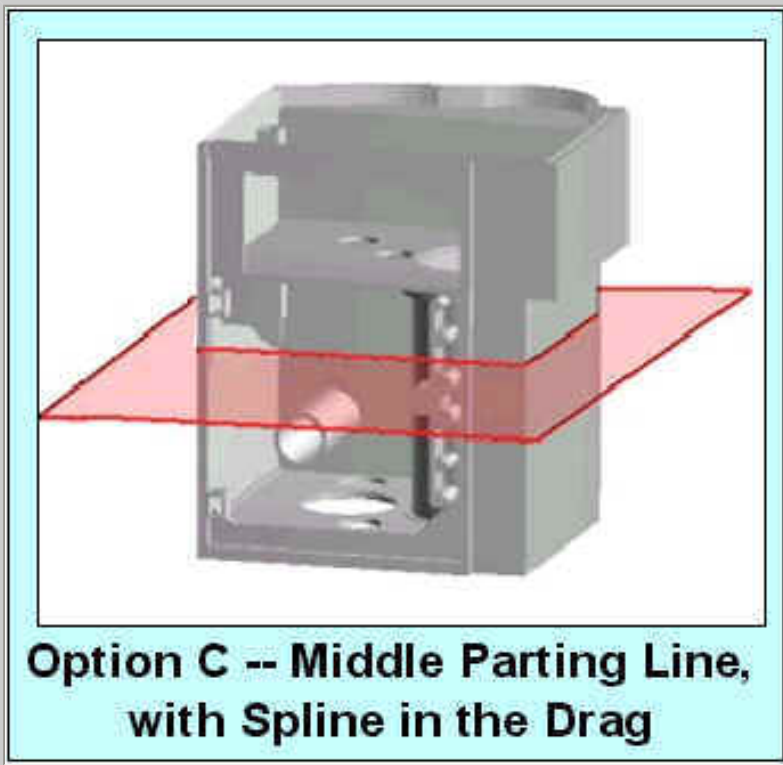

In Option C, the spline section is oriented down in the drag (the lower mold cavity). This orientation minimizes the risk of flaw segregation in the spline feature.

But this mold design has one critical shortcoming --

- The parting line is at the midsection of the mold. The molten metal drops down into the mold and will produce more turbulent flow, introducing bubbles and oxides.

For this reason, Option C is not the best mold design.

[Go Back to the Options Page](#)



[Back](#)

17



Copyright 2001 by the American Foundry Society All rights reserved.

Address comments to: jss@afsinc.org

[Return to AFS
Home Page](#)

Last Modified: August, 2001 by STG



[Page 1](#)

In Cooperation with
[Eck Industries](#)

